

UNIVERSAL JOINT DIMENSIONAL DATA



CONTENTS

How to identify and measure universal joint kits	Pg 3
Universal joint types	Pg 4 - 5
Lubrication points / Bearing cap types	Pg 5
Universal joint dimensional data	Pg 6 - 26
Application Listing	Pg 27 - 46
Part no. index	Pg 47 - 51



****E. & O.E****

HOW TO IDENTIFY AND MEASURE UNIVERSAL JOINT KITS

1. Determine UJ kit type by comparing with diagrams on next page.
2. Measure Bearing cap diameter (C).
 - (a) Important – note: measure with caps compressed ensuring needle rollers are not dislodged.
 - (b) Some kit types have 2 varying cup diameters.
3. Measure width over caps (W2) & over flanges (W1) as required for kit type – see diagrams.
4. For wing type bearing caps (3, 4 & 6) measure hole centres (D2 & D3).
5. Confirm bearing cap type & quantity.
6. Compare / match with data tables and record part number.
7. Contact BEATTYS GROUP to confirm availability.

UNIVERSAL JOINT TYPES

Fig 1

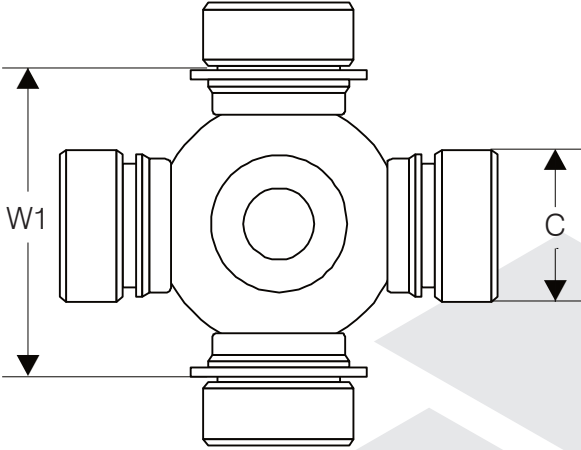

Fig 2

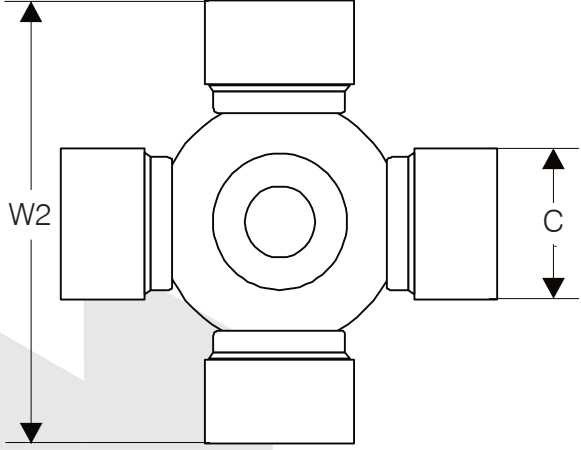

Fig 3

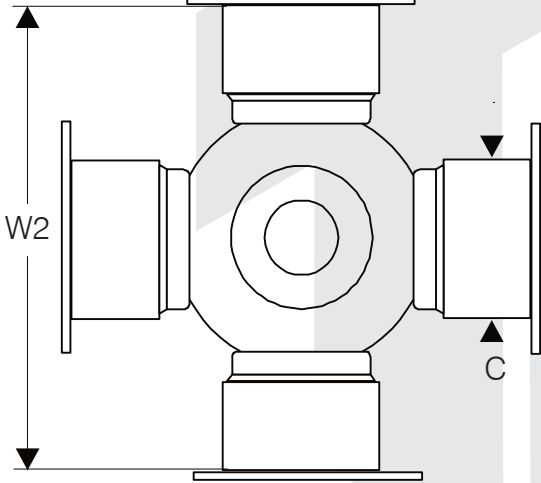

Fig 4

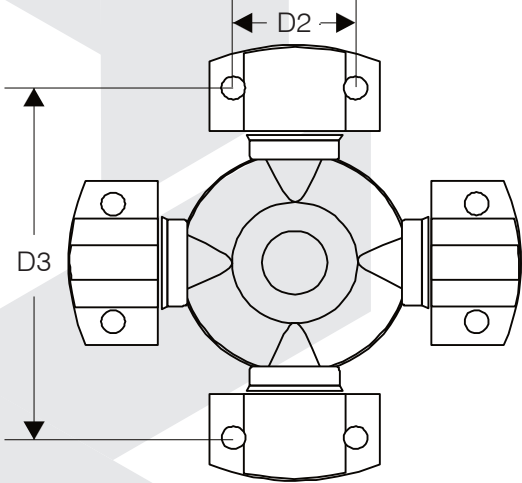

Fig 5

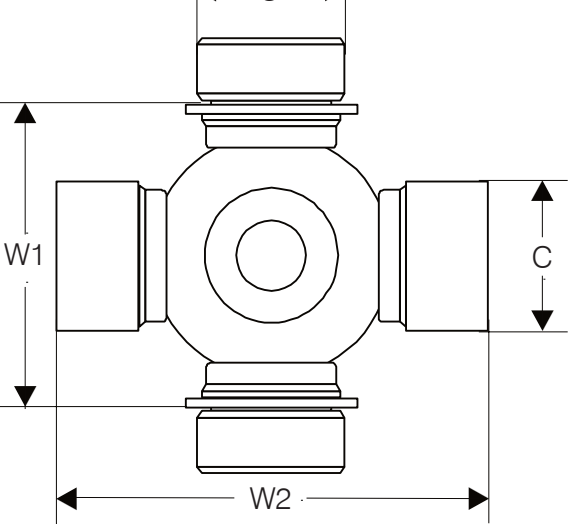
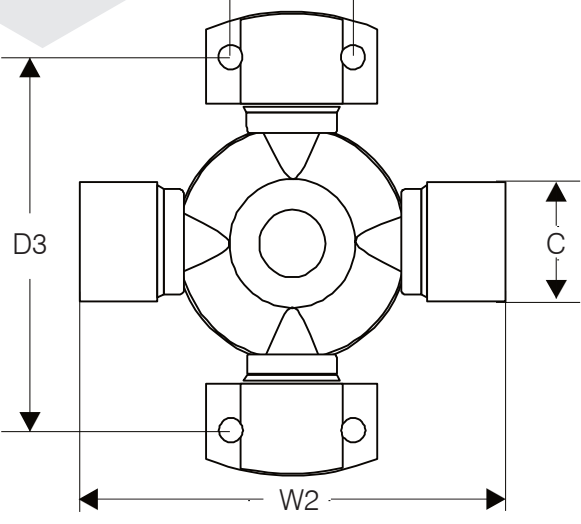

Fig 6



UNIVERSAL JOINT TYPES

Fig 7

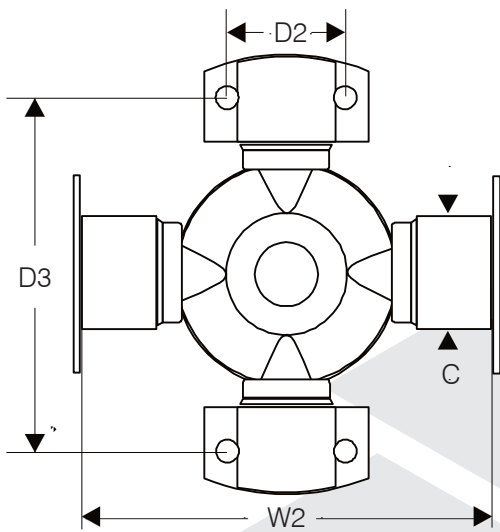

Fig 8

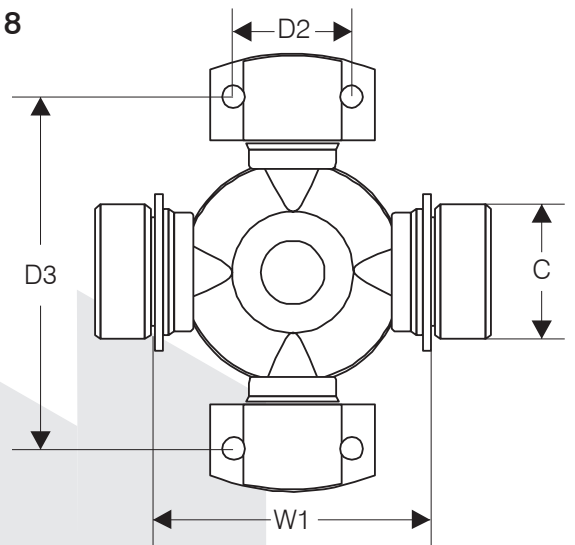

Fig 9

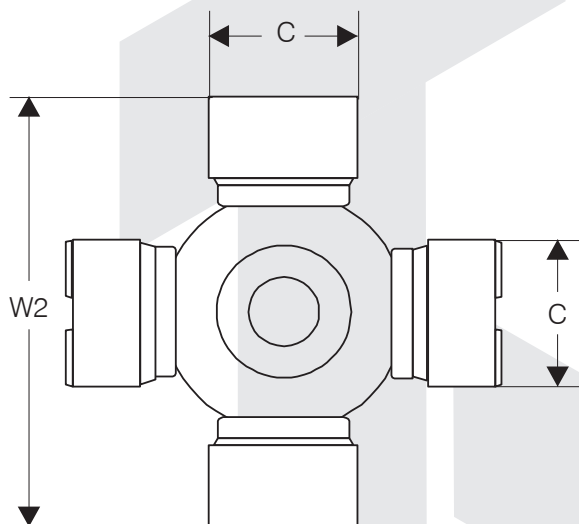
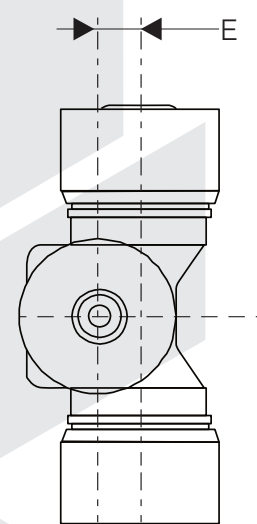
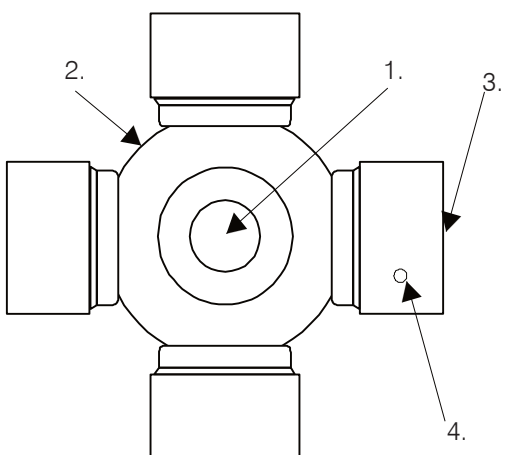

Fig 10



LUBRICATION POINTS



BEARING CAP TYPES

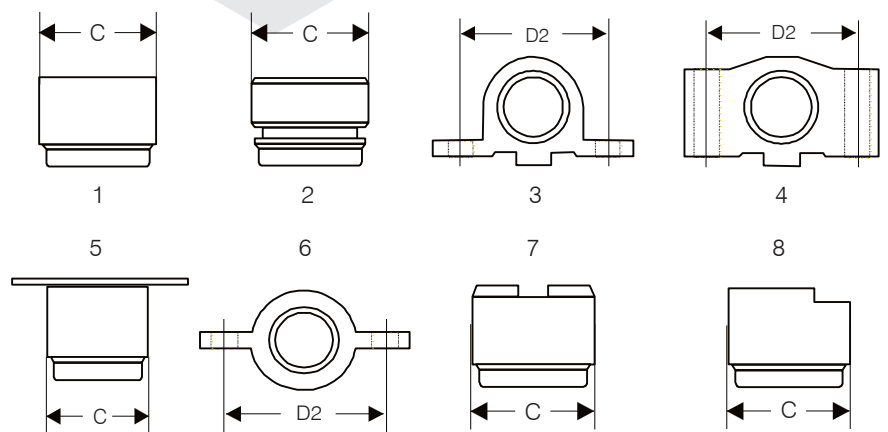

T = Tapped

D = Drilled & C/Bore

UNIVERSAL JOINT DIMENSIONAL DATA

C	W1	W2	D2	D3	CAP QTY	CAP TYPE	FIG	PART NO.	LUBE	NOTES / APPLICATION
14		36			4	1	2	802037	1	ELBE 204
15		38			4	1	2	902001	NON	STAKED STEERING
15		40			4	1	2	901540	NON	STAKED STEERING
15		47			4	1	2	901547	NON	STAKED STEERING
16	27	41			4	2	1	701627C	NON	KAWASAKI
16		38			4	1	2	902002	NON	STAKED STEERING
16		40			4	1	2	902020	NON	STAKED
17		41			4	1	2	802024	1	ELBE 105
17		41			4	1	2	802024-1A	3	ELBE 105 - LUBE IN CUP
18		47			4	1	2	K5-A587	1	WALTERSCHEID P.T.O
19		44			4	1	2	902025	NON	STAKED STEERING
19		44			4	1	2	K5-A701	1	CIRCLIP
19		48			4	1	2	U-901	1	373.20 GWB/ELBE 106
19		48			4	1	2	U-901S	NON	STAKED STEERING
19		48			4	1	2	U-901SL	1	STAKED - GREASABLE
19		48			4	1	2	U-901C	1	CIRCLIP
19		54			4	1	2	901954	NON	STAKED BMW
19.05		52			4	1	2	K5-A546	1	0500 SERIES
20	29.8				4	2	1	901001	1	JAPANESE P.T.O
20	32				4	2	1	902032IC	1	PTO - WITHOUT CIRCLIPS
20	38.1				4	2	1	RUJ-1780	NON	NISSAN
20	40				4	2	1	901004	NON	TOYOTA T.C.M
20		44.2			4	1	2	802001	1	MOTO GUZZI
20		44.7			4	1	2	902014	NON	KUBOTA
20		47			4	1	2	920047	3	SINOTRUK STEERING
20		50			4	1	2	K5-A844	1	BYPY AGRICULTURAL
20		52.4			4	1	2	902004	NON	STAKED NISSAN
20		55			4	1	2	K5-A510	3	MAZDA
20		57			4	1	2	K5-A517	3	TOYOTA
20		57.5			4	1	2	K5-A549	1	M.D.P-JAPANESE P.T.O
20.07		59.8			4	1	2	902005	NON	STAKED SUZUKI
20.5		56.5			4	1	2	K5-A551	1	U.D STEERING
20.9		52			4	1	2	902152	NON	STAKED TOYOTA/LEXUS
22	34.3				4	1	2	RUJ-1800	3	KAWASAKI
22	35.5				4	2	1	404002	3	STAKED-REPL:TOY,NISSAN
22	38.5				4	2	1	401005	2	STAKED-REPL: MAZDA
22	40				4	2	1	RUJ-1501	3	MITSUBISHI FORKLIFT
22		49			4	1	2	802002	1	MOTO GUZZI

UNIVERSAL JOINT DIMENSIONAL DATA

C	W1	W2	D2	D3	CAP QTY	CAP TYPE	FIG	PART NO.	LUBE	NOTES / APPLICATION
22		50.2			4	1	2	802003	1	MOTO GUZZI
22		50.2			4	1	2	K5-A615	1	GWB 373.20
22		52			4	1	2	802047	NON	STAKED-REPL: VOLVO
22		54			4	1	2	K5-A588	1	BYPY P.T.O
22		55			4	1	2	K5-A589	1	WALTERSCHEID P.T.O
22		57.5			4	1	2	902021	NON	STAKED-REPL: TOYOTA
22		58			4	1	2	802004	1	ELBE 107
22		58			4	1	2	802004-1A	3	ELBE 107 - GREASE IN 2 CUPS
22		58.9			4	1	2	U-166	1	473.30 SERIES GWB
22		60			4	1	2	902260	NON	STAKED MAZDA
22		62			4	1	2	K5-A553	1	
22		64			4	1	2	902006	NON	STAKED
22		65			4	1	2	K5-A554	NON	
22		67			4	1	2	902007	NON	STAKED
22		76			2	1		802067	1	WALTERSCHEID W2280
24		61			2	1	2			WIDE ANGLE
22.06		61.8			4	1	2	U-196	NON	STAKED-WASHER TYPE
22.2		73.6			4	1	2	5-264X	1	1FR SERIES
22.22		61.93			4	1	2	CPL-10N	3	
22.5	37.65				4	2	1	RUJ-1500	3	MAZDA
23	49				4	2	1	RUJ-1797	NON	SUBARU
23		58.2			4	1	2	U-160	1	INDUSTRIAL
23.8	38.1				4	2	1	5-170X	1	1000 SERIES
23.8	38.1				4	2	1	5-170X-1A	3	1000 SERIES
23.8	38.1				4	2	1	5-170XSP	NON	1000 SERIES - LUBE FOR LIFE
23.8	38.1				2	2	1	5-430X	1	1000 - L6N SERIES
24.6	36.8				2	2				
23.8		61.2			4	1	2	K5-A64	1	1140 SERIES P.T.O
23.8		61.2			4	1	2	K5-LGB80R	2	1140 SERIES SPICER
23.8		61.2			4	1	2	K5-LGB80R-1A	3	1140 SERIES SPICER
23.8		61.2			4	1	2	K5-LGB80RP	2	1140 SERIES PERFORMANCE
23.8		61.2			4	1	2	K5-GB150	NON	1140 SERIES LUBE FOR LIFE
23.8		61.2			2	1	2	407001	3	1140 SERIES SPICER TO
25	42.9				2	2	5			SUZUKI RUJ-1795
23.8		61.2			2	1	5	RUJ-1766	2	1140 SERIES SPICER TO 17R SERIES MECHANICS
25.4	43.64				2	2				
23.8		62.5			4	1	2	U-149	NON	AXLE - SEALED FOR LIFE

UNIVERSAL JOINT DIMENSIONAL DATA

C	W1	W2	D2	D3	CAP QTY	CAP TYPE	FIG	PART NO.	LUBE	NOTES / APPLICATION
23.8		62.5			4	1	10	U-149-3	NON	AXLE - 3MM OFFSET
23.8		65.8			4	1	2	902008	1	STEERING - REPL: HINO
23.8		86			4	1	2	802063	1	BYPY 4 SERIES W/ANGLE
23.84		54.8			4	1	2	UJ641	NON	TRIUMPH ROCKET - SEALED
24	48				4	2	1	404003	2	STAKED-REPL: MAZDA
24		56.5			4	2	1	902456	NON	STAKED - BMW
24		88			4	1	2	902488	NON	STAKED MERCEDES
24		62.5			4	1	2	902009	NON	STAKED
24		63.3			4	1	2	K5-A532	NON	ALFA ROMEO
24		72			4	1	2	902472	NON	STAKED MAZDA
24		74.5			4	1	2	902010	NON	STAKED
24		78			4	1	2	902011	NON	STAKED
24		91			2	1	2	802068	1	WIDE ANGLE
27		75			2	1				WALTERSCHEID W2380
24.5		74.5			4	1	2	902474	NON	STAKED LEXUS
24.6	36.8				4	2	1	114-1004	1	L6N SERIES P.T.O / 1AG
24.6	42.87				4	2	1	114-1501	1	CATERPILLAR PTO
24.7	41.7				4	2	1	401006	3	STAKED-REPL: NISSAN
24.7		66			4	1	2	701006	NON	STAKED NISSAN
25	42.9				4	2	1	RUJ-1795	3	SUZUKI
25	43.6				4	2	1	RUJ-1784	3	MAZDA
25	43.6				4	2	1	RUJ-1784SP	NON	MAZDA - NON LUBE
25	44				4	2	1	RUJ-1781	3	NISSAN/SUBARU
25	56				4	2	1	RUJ-2040	2	NISSAN
25	58.7				4	2	1	901005	1	TOYOTA T.C.M
25		63.8			4	1	2	RUJ-1783	3	mitsubishi
25		63.8			4	1	2	RUJ-1783SP	NON	MITSUBISHI - SEALED
25		63.9			4	1	2	902018	NON	SUZUKI
25		64			4	1	2	K5-A557	3	HONDA
25		72			4	1	2	70GUA6	1	AGRI
25		76.5			4	1	2	RUJ-2045	1	MITSUBISHI
25		77			4	1	2	K5-A558	1	P.T.O
25		77.8			4	1	2	K5-A559	2	MITSUBISHI
25.4	43.64				4	2	1	RUJ-1786	3	17R SERIES MECH.-HOLDEN
25.4	43.64				4	2	1	RUJ-1786R	3	17R SERIES - W/-THRUST PADS
25.4	43.64				2	2	5	5-248X	1	17R SERIES MECHANICS TO
26.99		61.93			2	1				1210 SERIES
25.4	43.64		33.34	44.86	2	2	8	RUJ-1764	3	17R SERIES MECHANICS TO
					2	3T				17C SERIES MECH

UNIVERSAL JOINT DIMENSIONAL DATA

C	W1	W2	D2	D3	CAP QTY	CAP TYPE	FIG	PART NO.	LUBE	NOTES / APPLICATION
25.4	43.64		33.34	52.78	2 2	2 3T	8	RUJ-1758	3	EARLY HOLDEN
25.4	46.8				4	2	1	401001	1	BENBOW P.T.O / 2AG
25.4	59.44				4	2	1	RUJ-2030	NON	2R SERIES
25.4	59.44				4	2	1	RUJ-2030R	NON	2R SERIES-W/- THRUST PADS
25.4	59.44				4	2	1	114-2101	2	2R SERIES GREASEABLE
25.4	59.44				2	2	5	RUJ-2032	2	2R SERIES TO
26.99		81.76			2	1				1310 SERIES
25.4	59.44				2	2	1	RUJ-2009	2	USE RUJ-2034
28.58	59.44				2	2				
25.4	59.44				2	2	5	RUJ-2034	2	2R SERIES MECH TO
28.58	59.44	81.76			2	2				25R SERIES MECH. & FORD
25.4	59.44		33.34	59.44	2 2	2 3T	8	114-2111	2	2R SERIES MECHANICS TO 2C SERIES MECHANICS
25.4	59.44		33.34	59.44	2	2	8	114-2111-1A	3	2R SERIES MECHANICS TO 2C SERIES MECHANICS
25.4	59.44		33.34	59.44	2	2	8	114-2114	2	2R SERIES MECHANICS TO 2C SERIES MECHANICS
25.4	59.44		33.34	59.44	2	2	8	114-2114-1A	3	2R SERIES MECHANICS TO 2C SERIES MECHANICS
25.4	59.44		36.52	69.85	2 2	2 3T	8	114-2198	NON	2R SERIES MECHANICS TO 3C SERIES MECHANICS
25.4		86			4	1	2	902024	1	KATO CRANE
26	46.6				4	2	1	RUJ-1776	NON	TOYOTA
26	48.2				4	2	1	RUJ-1794	NON	NISSAN
26	55.5		33.3	60	2 2	2 4	8	9026BL	2	MITSI BULLDOZER
26	55.96				4	2	1	RUJ-2016	2	TOYOTA
26	55.96				4	2	1	RUJ-2016SP	NON	TOYOTA - NON LUBE
26		69.8			4	1	2	U-741	1	287.00 SERIES GWB
26.5	50.4				4	2	1	RUJ-2049	NON	MAZDA E2200
26.99	46.04				4	2	1	RUJ-1788	1	1200 SERIES P.T.O
26.99	55.57				4	2	1	5-174X	NON	1310 SERIES - AXLE JOINT
26.99	55.57				4	2	1	5-260X	1	1310 SERIES - AXLE W/- SEALS
26.99		61.93			4	2	1	5-443X	3	1210 SERIES
26.99	60.32	81.76			4	2	1	RUJ-2027	2	1310 SER. & FORD CLEVELAND
26.99		74.61			4	1	2	K5-L4R	2	1300 SERIES
26.99		74.61			4	1	2	K5-L4RP	2	1300 SERIES PERFORMANCE
26.99		74.64			4	1	2	902275	NON	CITROEN WITH HOLE THRU CROSS

UNIVERSAL JOINT DIMENSIONAL DATA

C	W1	W2	D2	D3	CAP QTY	CAP TYPE	FIG	PART NO.	LUBE	NOTES / APPLICATION
26.99		74.61			4	1	2	K5-GB36R	1	1300 SERIES P.T.O / 4AG
26.99		81.76			4	1	2	K5-13XR	2	1310 SERIES
26.99		81.76			4	1	2	K5-13XR-1A	3	1310 SERIES - LUBE ON CAP
26.99		81.76			4	1	2	K5-13XRRS	NON	1310 SERIES NON LUBE
26.99		81.76			4	1	2	K5-13XRR	2	1310 SERIES - THRUST WASHERS
26.99		81.76			4	1	2	5-625XSD	NON	1310 SERIES PERFORMANCE - DANA
26.99		81.76			4	1	2	5-625XSG	NON	1310 SERIES PERFORMANCE
26.99		81.76			2	1	5	K5-A530	2	1310 SERIES TO
27.38	54				2	2				21R SERIES MECHANICS
26.99		81.76			2	1	5	K5-A530XSD	NON	1310 SERIES TO 21R SERIES
27.38	54				2	2				MECHANICS - SEALED, DANA
26.99		81.76			2	1		K5-A522/13XR	2	1310 SERIES SPICER TO
28	55.96	80			2	1	2			DAIHATSU/NISSAN
26.99		81.76			2	1	5	114-2531	1	1310 SERIES TO
28.58	54				2	2				2.5R SERIES - AMERICAN
26.99		81.76			2	2	5	RUJ-2039	2	1310 SERIES TO
28.58	59.44	81.76			2	1				9" FORD DIFF. (1310 - 25R)
26.99		81.76			2	2	5	RUJ-2039SP	2	1310 SERIES TO 9" FORD
28.58	59.44	81.76			2	1				DIFF. (1310 - 25R) HEAVY DUTY
26.99		81.76			2	1	2	5-632XSD	NON	1310 SERIES TO 9" FORD DIFF - DANA
28.58		81.76			2	1	2			PERFORMANCE
26.99		81.76			2	1	5	5-150X	2	1310 SERIES TO
28.58	65.1	92.08			2	2				3R SERIES & 9" FORD DIFF
26.99		81.76			2	1	2	5-150XNF	2	1310 SERIES TO 9 INCH
28.58		66.67			2	1				
26.99		81.76			2	1	5	RUJ-2100-13XR	2	1310 TO TOYOTA/ISUZU
29	52				2	2				EXTRA CIRCLIPS INCLUDED
26.99		81.76			2	1	2	5-134X	2	1310 SERIES TO
26.99		92.08			2	1				1330 SERIES
26.99		81.76			2	1	2	5-134XSP	NON	1310 - 1330 SERIES
26.99		92.08			2	1				LUBE FOR LIFE
26.99		81.76			2	1	2	5-460X	2	1310 SERIES SPICER TO
30.16		92.08			2	1				1350 SERIES SPICER
26.99		81.76			2	1	6	5-291X	2&3	1310 SERIES TO
			33.34	59.53	2	3T				2C SERIES MECHANICS
26.99		81.76			2	1	6	5-356X	2	1310 SERIES TO
			36.52	69.85	2	3T				3C SERIES MECHANICS

UNIVERSAL JOINT DIMENSIONAL DATA

C	W1	W2	D2	D3	CAP QTY	CAP TYPE	FIG	PART NO.	LUBE	NOTES / APPLICATION
26.99		92.08			4	1	2	RUJ-3002	2	1330 SERIES
26.99		92.08			4	1	2	RUJ-3002S	NON	1330 SERIES LUBE FOR LIFE
26.99		92.08			4	1	2	5-618XSG	NON	1330 SERIES PERFORMANCE
26.99		92.08			2	2	5	114-596	2	1330 SERIES TO
28.58	65.1				2	1				3R SERIES MECHANICS
26.99		92.08			2	2	5	114-596SP	NON	1330 SERIES TO
28.58	65.1				2	1				3R SERIES MECHANICS - SEALED
26.99		92.08			2	1	5	5-355X	2	1330 SERIES TO
28.58	66.68				2	2				7290 DETROIT
26.99		92.08			2	2	5	RUJ-3000	2	1330 SERIES TO 9" FORD DIFF
28.58		92.08			2	1				
26.99		92.08			2	1	2	RUJ-3000SP	NON	1330 SERIES TO 9" FORD
28.58		92.08			2	1	2			HEAVY DUTY
26.99		92.08			2	1	2	5-633XSP	NON	1330 SERIES PERFORMANCE TO
28.58		92.08			2	1				9" FORD DIFF - PERFORMANCE
26.99		92.08			2	1	2	K5-A537	2	1330 SERIES TO
30.16		92.08			2	1				1350 SERIES
26.99		92.08			2	1	6	5-314X	2	1330 SERIES TO
			36.52	69.85	2	3T				3C SERIES MECHANICS
27	49.02				4	2	1	901012	NON	NISSAN NAVARA
27		65.3			4	1	2	K5-A561	3	MITSUBISHI
27		70			4	1	2	K5-A590	1	WALTERSCHEID BYPY P.T.O
27		70			4	1	2	K5-A590S	NON	WALTERSCHEID BYPY P.T.O - SEALED
27		70			4	1	2	802044-011	4	JOHN DEERE - STEER AXLE
27		71			4	1	2	802048	NON	STAKED - REPL: FORD
27		71			4	1	2	802059	1	
27		74			4	1	2	902774	NON	MERC SPRINTER
27		74.5			4	1	2	K5-A727	1	687.15 SERIES GWB
27		74.5			4	1	2	K5-A727R	1	687.15 SERIES GWB WITH T/ WASHERS
27		74.5			4	1	2	K5-A727SP	NON	687.15 SERIES GWB - SEALED
27		80			4	1	2	802049	2	STAKED - REPL: VW
27		80			4	1	2	902026	1	HYUNDAI
27		80			4	1	2	902780	NON	STAKED - REPL: FORD TRANSIT
72		82			4	1	10	902782	3	FIAT OFFSET AXLE
27		88			4	1	2	902788	NON	STAKED
27		94			2	1		802069	1	WALTERSCHEID W2480
32		76			2	1	2			WIDE ANGLE

UNIVERSAL JOINT DIMENSIONAL DATA

C	W1	W2	D2	D3	CAP QTY	CAP TYPE	FIG	PART NO.	LUBE	NOTES / APPLICATION
27.38	54				4	2	1	RUJ-2038S	NON	21R SERIES - SOLID SPORTS
27.38	54				4	2	1	RUJ-2038R	2	21R SERIES - W/-THRUST PADS
27.38	54				2	2	5	RUJ-2029	2	21R SERIES MECHANICS TO
28.58	59.44	81.76			2	2				9" FORD DIFF. (21R-25R)
27.38	54				2	2	5	405002	2	21R SERIES TO
28.58		92.08			2	1				9" FORD DIFF
27.9	50.7				4	2	1	401007	2	STAKED - REPL: NISSAN
28	48				4	2	1	U-172	3	
28	51							702851		KIA
28	53				4	2	1	U-728	2	BENZ
28	54				4	2	1	U-728-1	2	BENZ
28	55.96				4	2	1	RUJ-2028	2	NISSAN
28	55.96				4	2	1	RUJ-2028SP	NON	NISSAN - NON LUBE
28	59.1				4	2	1	RUJ-2023	2	MAZDA
28	59.1				4	2	1	RUJ-2023SP	NON	MAZDA - NON LUBE
28		71.5			4	1	2	802005	1	ELBE 109 - OLD STYLE
28	75				4	2	1	902875	NON	TOYOTA HIACE
28		78			4	1	2	902878	NON	NISSAN 300ZX - STAKED
28		80			4	1	2	K5-A522	1	DAIHATSU/NISSAN USE RUJ-2028
28.5		70.9			4	1	2	802039	1	ELBE 109 - NEW STYLE
28.5		70.9			4	1	2	802039-1A	4	ELBE 109 - LUBE ON SIDE OF CUP
28.5		70.9			4	1	2	802039-3A	3	ELBE 109 - LUBE ON END OF CUP
28.5		78			4	1	2	K5-A562	1	MITSUBISHI
28.55	65.4				4	2	1	RUJ-2051	NON	185.10 SERIES GWB
28.58	54				4	2	1	114-2501	3	25R JAP DOUBLE CARDAN
28.58	59.44				4	2	1	RUJ-2500	2	25R SERIES MECHANICS
28.58	59.44				4	2	1	RUJ-2500R	NON	25R SERIES MECH W/- THRUST PADS (25R-FORD 9")
28.58	65.1				4	2	1	114-3105	2	3R SERIES MECHANICS / 5AG
28.58	65.1				4	2	1	114-3105SP	NON	3R SERIES MECHANICS / 5AG - SEALED
28.58	65.1				2	2	1	405001	NON	3R SERIES MECHANICS TO
28.58	66.67				2	2				7290 SERIES DETROIT
28.58	65.1				2	2	5	903049	2	3R SERIES MECHANICS TO
28.58		92.08			2	1				9" FORD DIFF.
28.58	65.1		36.52	69.85	2	2	8	114-3102	2	3R MECHANICS SERIES TO
					2	3T				3C SERIES MECHANICS

UNIVERSAL JOINT DIMENSIONAL DATA

C	W1	W2	D2	D3	CAP QTY	CAP TYPE	FIG	PART NO.	LUBE	NOTES / APPLICATION
28.58	65.1		36.52	69.85	2	2	8	114-3120	2	3R MECHANICS SERIES TO 3C SERIES MECHANICS
28.58	65.1				2	2	5	901153	2	3R MECHANICS SERIES TO 1350 SERIES
30.16		92.06			2	1				
28.58	66.67				4	2	1	114-232	2	7290 SERIES DETROIT
28.58	66.67				4	2	1	114-232SP	2	7290 SERIES - LUBE FOR LIFE
28.58	82.55				4	2	1	RUJ-4000	2	4R MECHANICS SERIES
28.58	82.55				2	2	8	RUJ-4002	2	COUNTERSUNK
			36.52	87.32	2	3D				
28.58	82.55				2	2	8	RUJ-4005	2	4R MECHANICS SERIES TO 4C SERIES MECHANICS
			36.52	87.32	2	3T				
28.58	82.55				2	2	8	114-4109	1	4R 4C HWD
			36.52	87.32	2	4				
28.58		66.67			4	1	2	CPL-14N	1	NEAPCO 2000 SERIES P.T.O
28.58		66.67			2	1	2	905375	2	1350 TO 7290
30.18		92.08			2	1				
28.58		77.9			4	1	2	K5-A519	1	TOYOTA
28.58		92.08			2	1	2	K5-A541	2	9" FORD DIFF. TO 1350 SERIES
30.16		92.08			2	1				
28.6	65.1				4	2	1	RUJ-2505	2	USE 114-3105
28.6		74.6			4	1	2	802035	1	
29	52				4	2	1	RUJ-2100-1A	3	TOYOTA
29	52				4	2	1	RUJ-2100R	1	TOYOTA WITH THRUST PADS
29	53.1				4	2	1	RUJ-2033	2	ISUZU
29	72				4	2	1	901013	2	RODEO
29		76.6			4	2	1	K5-A842	1	GREAT WALL
29		80			4	1	2	802032	1	AGRICULTURAL
29.5	56				4	2	1	U-729	NON	BENZ
30	58.25				4	2	1	901002	1	MITSUBISHI
30	74				4	2	1	901014	1	PAJERO
30		78.2			4	1	2	K5-A585	1	MITSUBISHI
30		79			4	1	2	802042	3	STEERING AXLE - OFFSET
30		81.7			4	1	2	U-742	1	287.10 SERIES GWB
30		83			4	1	2	802006	3	ELBE 110
30		83			4	1	2	802006-1A	3	ELBE 110 - LUBE IN END OF CUP
30		83			4	1	2	802006-011	4	ELBE 110 CENTRE YOKE LUBE THROUGH 1 CAP
30		86.7			4	1	2	903087	1	MAN

UNIVERSAL JOINT DIMENSIONAL DATA

C	W1	W2	D2	D3	CAP QTY	CAP TYPE	FIG	PART NO.	LUBE	NOTES / APPLICATION
30		86.7			4	1	10	903087A	1	MAN - OFFSET
30		88			4	1	2	903088	2	FOTON
30		92			4	1	2	903092	NON	STAKED - FORD TRANSIT
30		96			4	1	2	369.10	NON	369.10 SERIES
30.16	55.57				4	2	1	5-297X	NON	1350 SERIES - AXLE JOINT
30.16		92.08			2	1	5	701153	2	3R / 1350
28.58	65.1				2	2				
30.16	65.1	92.08			2	1	5	RUJ-3001	2	1350 SERIES
30.16	65.1	92.08			2	2				HAS VARIOUS COMBINATIONS
30.16		92.08			4	1	2	5-178XR	2	1350 SERIES - THRUST WASHERS
30.16		92.08			4	1	2	5-178XRRS	NON	1350 SERIES - THRUST WASHERS - SEALED
30.16		92.08			4	1	2	5-178X-1A	3	1350 SERIES
30.16		92.08			4	1	2	5-627XSG	NON	1350 PERFORMANCE
30.16		92.08			4	1	2	5-627XSD	NON	1350 PERFORMANCE - DANA
30.16		106.35			4	1	2	5-641XSG	NON	1410 PERFORMANCE
30.16		106.35			4	1	2	5-64XSD	NON	1410 PERFORMANCE - DANA
30.16		106.35			4	1	2	K5-GB10RR	2	1410 SERIES - THRUST WASHERS
30.16		106.35			4	1	2	K5-GB10RRS	NON	1410 SERIES - THRUST WASHERS - SEALED
30.16		106.35			4	1	2	K5-GB10R-4A	3	1410 SERIES - LUBE THROUGH 4 CAPS
30.16		106.35			4	1	2	930106	NON	1410 SERIES STAKED - MERC/IVECO/VW
30.16	79.37	106.35			2	1	1	RUJ-4008	2	1410 SERIES - COMBINATION
30.16		106.35			2	1	5	5-357X	2	1410 SERIES TO
31.35	76.2				2	2				5380 SERIES DETROIT
30.16		106.35			2	1	6	5-345X	2	1410 SERIES TO
			36.52	87.32	2	4				4C SERIES MECHANICS
30.16		106.35			2	1	6	5-346X	2	1410 SERIES TO
			36.52	87.32	2	3T				4C SERIES MECHANICS
30.18	61.11				4	2	1	5-7166X	NON	1350WJ SPL AXLE - JEEP WRANGLER
30.2		80			4	1	2	K5-A591	1	BYPY P.T.O
30.2		81.8			4	1	2	802038	1	GWB 687.20 SERIES
30.2		81.8			4	1	2	802038R	1	GWB 687.20 SERIES THRUST WASHERS
30.2		81.8			4	1	2	802038S	NON	GWB 687.20 SERIES NON LUBE
30.2		99.4			4	1	2	802064	1	BYPY 6 SERIES WIDE ANGLE

UNIVERSAL JOINT DIMENSIONAL DATA

C	W1	W2	D2	D3	CAP QTY	CAP TYPE	FIG	PART NO.	LUBE	NOTES / APPLICATION
31		88.35			4	1	2	703188	3	MERC STAKED
31.35	50.8				4	2	1	114-162	1	CHRYSLER
31.35	76.2				4	2	1	RUJ-4007	2	5380 SERIES DETROIT
31.75		81.36			4	1	2	CP35N	3	NEAPCO 2200
31.75		93			4	1	2	903293-1	2	
31.75		102			4	1	2	K5-A563	1	MITSUBISHI
32	59.95				4	2	1	RUJ-3003	1	MAZDA
32	64				4	2	1	RUJ-2041	2	TOYOTA
32	64				4	2	1	RUJ-2041R	2	TOYOTA WITH THRUST PADS
32	68.2				4	2	1	901003	1	NISSAN PATROL 1988-
32	87				4	2	1	901015	2	FURUKAWA
32	87				2	2	2	912004	2	KOMATSU/FURUKAWA / 5C
			42.85	88.9	2	4				
32		76			4	1	2	K5-A592	1	WALTERSCHEID
32		86			4	1	2	802027	NON	FORD TRACTOR
32		93			4	1	2	903293	2	
32		95.6			4	1	2	802031	2	SCHINDLER TRACTOR
32		106			2	1	2	802070	1	WALTERSCHEID W2580
36		89			2	1				WIDE ANGLE
32		107			4	1	6	K5-A564	2	NISSAN
33		93			4	1	2	902013	1	ISUZU
33		103			4	1	2	K5-A841	1	ISUZU
33.35	84.15				4	2	1	114-5109	2	5R SERIES MECHANICS
33.35	84.15				2	2	8	114-5110	2	5R SERIES MECHANICS TO
			42.85	88.9	2	3D				5C SERIES MECHANICS
33.35	84.15				2	2	8	114-5132	2	5R SERIES MECHANICS TO
			42.85	88.9	2	3T				5C SERIES MECHANICS
33.35	84.15				2	2	8	114-5154	2	5R SERIES MECHANICS TO
			42.85	88.9	2	4				5C SERIES MECHANICS
33.35	109.5				4	2	1	114-6135	2	6R SERIES MECHANICS
33.35	109.5				2	2	8	114-6107	2	6R SERIES MECHANICS TO
			42.85	114.3	2	3T				6C SERIES MECHANICS
33.35	109.5				2	2	8	114-6150	2	6R SERIES MECHANICS TO
			42.85	114.3	2	4				6C SERIES MECHANICS
33.35	70.64				4	2	1	CP44R	2	ROCKWELL P.T.O./44N
33.4		96			4	1	2	903396	1	TOYOTA DYNA
34	56				4	2	1	RUJ-3004	1	WALTERSCHEID

UNIVERSAL JOINT DIMENSIONAL DATA

C	W1	W2	D2	D3	CAP QTY	CAP TYPE	FIG	PART NO.	LUBE	NOTES / APPLICATION
34		89			4	1	2	802045	1	MERCEDES BENZ
34		96			4	1	10	802020	4	AXLE - OFFSET TRUNNIONS
34		97			4	1	2	802007	1	ELBE 112 - OLD STYLE
34		97			4	1	2	802007-011	4	ELBE 112 - OLD STYLE
34		106.5			4	1	2	802028	1	AGRICULTURAL
34		107			4	1	2	U-188	2	
34.93		92			4	1	2	K5-A729	1	GWB 687.25 SERIES
34.93		92			4	1	2	K5-A729SP	NON	GWB 687.25 SERIES - NON LUBE
34.93	74.17				4	2	1	K5-A808	NON	AXLE JOINT
34.93	76.2				4	2	1	5-88X	2	1480 SERIES - AXLE JOINT
34.93	94.03				4	2	1	5-3212X	1	1555WJ SERIES, DODGE RAM
34.93		106.38			4	1	2	K5-A538	1	1480 SERIES P.T.O.
34.93		106.38			4	1	2	K5-A730	1	GWB 687.30 SERIES
34.93		106.38			4	1	2	K5-A730-1A	3	GWB 687.30 SERIES - LUBE IN CUP
34.93		106.38			4	1	2	K5-A730R	1	GWB 687.30 SERIES - T/ WASHERS
34.93		106.38			4	1	2	K5-A730S	NON	GWB 687.30 SERIES - NON LUBE
34.93		106.38			4	1	2	5-188X	2	1480 SERIES
34.93		106.38			4	1	2	5-188XR	2	1480 SERIES - THRUST WASHERS
34.93		106.38			2	1	6	5-347X	2	1480 SERIES TO
			42.85	88.9	2	4				5C SERIES MECHANICS
34.93		106.38			2	1	6	5-348X	2	1480 SERIES TO
			42.85	88.9	2	3T				5C SERIES MECHANICS
34.93		126.2			4	1	2	5-155X	2	1550 SERIES SPICER
34.93		126.2			4	1	2	5-155XR	2	1550 SERIES - THRUST WASHERS
34.93		126.2			2	1	6	5-220X	2	1550 SERIES TO
			42.85	114.3	2	3T				6C SERIES MECHANICS
34.93		126.2			2	1	6	5-221X	2	1550 SERIES TO
			42.85	114.3	2	4				6C SERIES MECHANICS
34.93		126.2			2	1	6	5-328X	2	1550 SERIES TO
			49.21	107.5	2	4				CP58WB SERIES
34.93		126.2			2	1	6	5-693X	2	1550 SERIES TO
			49.21	107.5	2	3T				CP58WB
35		87			4	1	2	802034	4	ELBE - OFFSET STEERING
35		94			4	1	2	802061	1	BYPY NEW 7 SERIES
35		96			4	1	10	802025	4	OFFSET STEERING - AXLE
35		96.8			4	1	2	U-743	1	587.10 SERIES G.W.B.
35		97			4	1	2	802040	1	ELBE 112 NEW STYLE
35		97			4	1	2	802040S	NON	ELBE 112 - NEW STYLE - SEALED

UNIVERSAL JOINT DIMENSIONAL DATA

C	W1	W2	D2	D3	CAP QTY	CAP TYPE	FIG	PART NO.	LUBE	NOTES / APPLICATION
35		99			4	1	2	K5-A566	1	HINO
35		104			4	1	2	K5-A567	1	ISUZU
35		106			4	1	2	802065	1	BYPY 8 SERIES W/ANGLE
35.5		119			4	1	2	K5-A568	2	NISSAN
36		89			4	1	2	K5-A593	1	WALTERSCHEID
36		97			4	7	2	K5-A523	1	ISUZU
36		104			4	1	2	K5-A569	1	mitsubishi
36		110.35			4	1	2	K5-A571	2	HINO
36		115.6			4	1	2	902015	1	HINO
37	71				4	2	1	RUJ-4009	1	MAZDA
38	62				4	2	1	U-730	1	MERCEDES BENZ
38		89.2			4	1	2	802008	NON	MERCEDES BENZ
38		104			4	1	2	K5-A572	1	MITSUBISHI
38		104			4	1	10	802030	3	469.30 SERIES - AXLE OFFSET
38		105.8			4	1	2	U-744	1	
38		106			4	1	2	802022	1	ELBE 113
38		106			2	1	6	950132	2	ELBE 113 TO 6C
			42.85	114.3	2	4				
38		107			4	1	10	802033	4	ELBE - OFFSET STEERING
38		110			4	1	2	U-752-1	1	UNIMOG
38		112			4	1	2	U-764	2	
38		119			4	1	2	369.3	2	FOR 369.30 DOUBLE JOINT
38		119			4	1	10	802026	1	GWB 369.30 OFFSET
38		148			4	1	2	802009	1	SCANIA - STRAIGHT BRACKETS
38		148			4	1	2	802010	1	SCANIA - 4.5 DEG BRACKETS
38		148			2	1	3	802023	2	SCANIA 802010 TO
47.63		134.94			2	5				1610 SERIES
38.89		109.6			4	1	2	CP55N	2	55N SERIES P.T.O.
39		116.4			4	1	2	K5-A632	2	FIAT
39		118			4	1	2	902031	2	CHINESE BUS
39		127			4	1	2	U-385	1	
39.7		115.9			4	1	2	K5-GB22R	2	1510 SERIES
39.7		115.9			4	7	3	K5-GB15R	2	1500 SERIES WITH BRACKETS
39.7		115.9			4	1	2	K5-A725	2	1630 SERIES
40		104.5			4	1	10	569-32	NON	OFFSET STEERING
40		111			4	1	2	902019	1	MITSUBISHI
40		115			4	1	2	K5-A639	1	ISUZU/HINO - EXTRA CIRCLIPS INCLUDED
40		118			4	7	3	K5-A573	2	TOYOTA

UNIVERSAL JOINT DIMENSIONAL DATA

C	W1	W2	D2	D3	CAP QTY	CAP TYPE	FIG	PART NO.	LUBE	NOTES / APPLICATION
41	111.2		49.21	117.6	2 2	2 4	8	912003	2	FURUKAWA & KOMATSU
41		108			4	1	2	802062	1	BYPY 9 SERIES
41		118			4	1	2	K5-A594	1	BYPY 10 SERIES
41		118			4	1	2	941118	1	FOTON
41.28		125.91			4	1	2	SPL90X	1	SPL90 SERIES
41.08		108			4	1	2	901900	1	BYPY 9 SERIES
41.28		128.63			4	1	2	CP750NP	1	ROCKWELL
41.28		142			4	1	2	5-165X	2	1650 SERIES
41.28		142	49.21	117.6	2 2	1 4	6	5-330X	2	1650 SERIES TO 7C SERIES MECHANICS
41.28		142	49.21	117.6	2 2	1 3T	6	5-331X	2	1650 SERIES TO 7C SERIES MECHANICS
41.28	110.8				4	2	1	114-7294	2	7R SERIES MECHANICS
41.28	110.8		49.21	117.6	2 2	2 4	8	114-7000RHWD	2	7R SERIES MECHANICS TO 7C HWD SERIES J.C.B.
41.28	167.9		49.21	174.63	2 2	2 4	8	114-8014	2	8R SERIES MECHANICS TO 8C HWD SERIES MECHANICS
42	72				4	2	1	U-747	1	MERCEDES BENZ
42		104			4	1	2	K5-A595	1	WALTERSCHEID
42		104.5			4	1	2	K5-A622	1	GWB 587.15 SERIES
42		104.5			4	1	2	K5-A622S	NON	GWB 587.15 SERIES - NON LUBE
42		106			4	1	2	802057	1	MERCEDES
42		106			4	1	2	802057S	1	MERCEDES - NON LUBE
42		110			4	1	10	802056	4	OFFSET STEERING
42		115			4	1	2	902017	1	ISUZU
42		117.5			4	1	2	802051	1	ELBE 148 SERIES
42		119.4			4	1	2	802054	1	GWB 687.35 SERIES
42		119.4			4	1	2	802054S	NON	GWB 687.35 SERIES - NON LUBE
42		123			4	1	2	802011	1	ELBE 115
42		125			4	7	9	K5-A574	1	ISUZU
43		128			4	7	3	K5-A575	1	NISSAN
43		136			4	7	9	K5-A547	1	NISSAN
44	84				4	2	1	U-737	1	MERCEDES BENZ
44		124.8			4	1	2	U-746	1	287.30 SERIES G.W.B.
44		126			4	1	2	902030	1	HINO
44		126.2			4	1	3	U-380	1	VOLVO - 1600 SERIES 3 BOLTS

UNIVERSAL JOINT DIMENSIONAL DATA

C	W1	W2	D2	D3	CAP QTY	CAP TYPE	FIG	PART NO.	LUBE	NOTES / APPLICATION
44		129			4	1	2	902022	1	mitsubishi
44		129			4	7	9	K5-A576	1	mitsubishi
44		134			4	1	10	369-37	NON	STEER AXLE
44		149			4	1	2	U-384	2	SCANIA - T60 SERIES
45		120.4			4	1	2	U-753	1	MERCEDES BENZ
45		124.8			4	1	2	802021	1	VOLVO 3 BOLT
45		125			4	1	10	802046	4	OFFSET AXLE JOINT
45		131			4	1	2	802012	1	ELBE 116
45		152			4	1	2	K5-A605	1	ELBE 118 SERIES
46		136			4	7	3	K5-A577	1	ISUZU
46		142			4	7	9	K5-A578	1	mitsubishi
47		124			4	7	3	K5-A579	1	HINO
47		130			4	7	3	903004	1	HINO
47		131			4	1	2	U-810	1	
47		138			4	7	3	K5-A580	1	HINO
47		140			4	8	2	K5-A827	1	BUS
47		142			4	1	2	802050	1	369.40 GWB SERIES
47		144.1			4	7	9	K5-A581	1	HINO
47.63		134.94			4	5	3	5-279X	2	1610 SERIES
47.63		134.94			4	5	3	5-279XP	2	1610 SERIES PREMIUM
47.63		134.94			2	5	3	5-674X	2	1610 SERIES TO
47.63		134.94			2	1				1610 - HALF ROUND W/- STRAPS
47.63		134.94			2	5	3	5-674XP	2	1610 SERIES TO 1610 - HALF ROUND
47.63		134.94			2	1				W/- STRAPS - PREMIUM
47.63		135.17			4	1	2	802043	1	GWB 687.40 SERIES
47.63		135.17			4	1	2	802043S	NON	GWB 687.40 SERIES NON LUBE
47.63		135.72	49.15	118.22				409003	3	
48		116.5			4	1	2	U-767	1	GWB 587.20 SERIES
48		116.5			4	1	2	U-767S	NON	GWB 587.20 SERIES - NON LUBE
48		126			4	1	2	U-765	1	MERCEDES BENZ
48		126			4	1	2	U-765S	NON	MERCEDES BENZ - NON LUBE
48		126			4	1	2	U-765-2A	3	MERCEDES BENZ - GREASE IN 2 CAPS
48		126			2	1	6	950232	3	158 SERIES TO 6CHWD
			42.85	114.3	2	4				
48		131.2			4	1	2	802013	1	KEMPF
48		135.4			4	1	2	948135	1	MAN

UNIVERSAL JOINT DIMENSIONAL DATA

C	W1	W2	D2	D3	CAP QTY	CAP TYPE	FIG	PART NO.	LUBE	NOTES / APPLICATION
48		135.4			4	1	2	948135S	NON	MAN - SEALED
48		145			4	7	9	K5-A582	1	ISUZU
48		161			4	1	2	802016	1	P400 SCANIA - 4.5 DEG BRACKETS
48		161			4	1	2	802016S	NON	P400 SCANIA - 4.5 DEG NON LUBE
49		135			4	5	3	803001	2	FIAT
49		155			4	7	3	U-501	2	FIAT
49.21		130.18			4	7	3	CP6N	2	ROCKWELL
49.21		150.72			4	1	2	CP850N	1	ROCKWELL
49.21		154.78			4	5	3	5-280X	2	1710 SERIES
49.21		154.78			4	5	3	5-280XP	2	1710 SERIES - PREMIUM
49.21		154.78			4	5	3	5-280XR	2	1710 SERIES - THRUST WASHERS
49.21		154.78			2	5	3	5-515X-CAT	2	1710 SERIES TO
49.21		155.08			2	8				CATERPILLAR
49.21		154.78			2	5	3	5-515X	2	USE 5-675X
49.21		157.08			2	1				
49.21		154.78			2	5	3	5-675X	2	1710 SERIES TO
49.21		157.08			2	1				1710 - HALF ROUND W/- STRAPS
49.21		154.78			2	5	3	5-675XP	2	1710 SERIES TO 1710 - HALF ROUND
49.21		157.08			2	1				W/- STRAPS - PREMIUM
49.21		154.78			2	5	3	5-675XR	2	1710 SERIES TO
49.21		157.08			2	1				1710 - HALF ROUND W/- STRAPS - THRUST WASHERS
49.21		154.78			2	5	3	403001	2	1710 SERIES TO
50.8		150.83			2	7				CP7N SERIES
49.21		154.78			2	5	7	409001	2	1710 SERIES TO
			71.44	123.83	2	4				8.5C SERIES MECHANICS
49.21		154.95			4	1	2	687-50	2	687.5
49.21		177.8			4	5	3	5-407X	2	1760 SERIES
49.21		177.8			2	5	3	5-677X	2	1760 SERIES TO
49.21		180.1			2	1				1760 SERIES - HALF ROUND
49.21		191.69			4	5	3	5-281X	2	1810 SERIES
49.21		191.69			4	5	3	5-281XP	2	1810 SERIES - PREMIUM
49.21		191.69			4	5	3	5-281XR	2	1810 SERIES - THRUST WASHERS
49.21		191.69			2	5	3	5-510X	2	USE 5-676X
49.21		194			2	1				
49.21		191.69			2	5	3	5-676X	2	1810 SERIES TO
49.21		194			2	1				1810 - HALF ROUND W/- STRAPS

UNIVERSAL JOINT DIMENSIONAL DATA

C	W1	W2	D2	D3	CAP QTY	CAP TYPE	FIG	PART NO.	LUBE	NOTES / APPLICATION
49.21		191.69		2	5	3		5-676XP	2	1810 SERIES TO 1810 - HALF ROUND
49.21		194		2	1					W/- STRAPS- PREMIUM
49.21		191.69			2	5	7	5-324X	2	1810 SERIES TO
			71.44	168.3	2	4				9C SERIES MECHANICS
50		118			4	1	2	802066	1	WALTERSCHEID 2700
50		131			4	1	2	U-811	1	
50		152.6			4	1	3	U-381	1	VOLVO - 1700 SERIES 3 BOLTS
50		153			4	1	2	U-739	1	
50		155			4	7	9	903006	1	ISUZU
50		159			4	7	3	K5-A583	2	HINO
50		164			4	1	2	U-386	2	SCANIA T70 SERIES
50		165			4	7	9	903003	2	HINO
50		180			4	4	4	RUJ-8002	NON	MECHANICS
52		133			4	1	2	U-756	1	GWB 587.30 SERIES
52		133			4	1	2	U-756S	NON	GWB 587.30 SERIES - NON LUBE
52		147.2			4	1	2	802029	1	687.45 SERIES G.W.B
52		147.2			4	1	2	802029S	NON	KEMPF
52		154			4	7	9	K5-A584	1	mitsubishi
52		160			4	1	2	903001	1	mitsubishi
52		170			4	7	9	903005	1	mitsubishi
52.3		174.7			2	2	8	CP20-RPLS	NON	RPL20 SERIES
			71.3	134.6	2	4				
52.3		174.7			2	2	8	CP20-RPLSG	NON	RPL20 SERIES - GENUINE
			71.3	134.6	2	4				
52.3		208.3			2	2	8	CP25-RPLS	NON	RPL25 SERIES
			71.3	134.6	2	4				
52.3		208.3			2	2	8	CP25-RPLSG	NON	RPL25 SERIES - GENUINE
			71.3	168.4	2	4				
53		135			4	1	2	U-761	1	ELBE 117 / MERCEDES BENZ
53		135			4	1	2	U-761S	NON	ELBE 117 / MERCEDES BENZ
53.5		155			4	7	9	903009	1	ISUZU
55		164			4	7	9	K5-A548	1	U.D. NISSAN
55		164			4	1	2	U-812	2	
55		164			4	1	2	SPL170X	1	SPL170
55		164			4	1	2	SPL170XP	NON	SPL170 - SEALED
55		169			4	7	9	903002	1	ISUZU
55.55		205.59			4	1	2	5-185X	2	1850 SERIES

UNIVERSAL JOINT DIMENSIONAL DATA

C	W1	W2	D2	D3	CAP QTY	CAP TYPE	FIG	PART NO.	LUBE	NOTES / APPLICATION
55.55		205.59	71.44	168.3	2 2	1 4	6	5-186X	2	1850 SERIES TO 9C SERIES MECHANICS
55.55		205.59	71.44	168.3	2 2	1 3T	6	5-187X	2	1850 SERIES TO 9C SERIES MECHANICS
55.55		205.59			4	5	3	5-308X	2	1880 SERIES
55.55		205.59	71.44	168.3	2 2	5 4	7	5-326X	2	1880 SERIES TO 9C SERIES MECHANICS
55.55		205.59	71.44	168.3	2 2	5 3T	7	5-327X	2	1880 SERIES TO 9C SERIES MECHANICS
57		144			4	1	2	U-813	1	GWB 587.36 SERIES
57		144			4	1	2	U-813S	NON	GWB 587.36 SERIES - NON LUBE
57		152			4	1	2	U-763	1	GWB 587.42 SERIES
57		152			4	1	2	U-763S	NON	GWB 587.42 SERIES - NON LUBE
57		152.6			4	1	3	803002	1	VOLVO-1800 SERIES 3 BOLTS
57		164			4	1	2	802019	1	P500 SCANIA-4.5 DEG BRACKETS
57		164			4	1	2	802019S	NON	P500 SCANIA-4.5 DEG NON LUBE
57		172			4	1	2	957172	1	IVECO
58		175			4	7	9	903008	1	HINO
59		167.4			4	1	2	802041	2	VOLVO-687.60 SERIES G.W.B
59		167.4			4	1	2	802041S	NON	VOLVO-687.60 SERIES G.W.B
59.1		167.49			4	5	3	5-124X	2	1800 SERIES
60		163			4	1	2	SPL250X	2	SPL250
60		163			4	1	2	SPL250XP	2	SPL250 - PREMIUM
60		170			4	7	3	K5-A630	2	FIAT-TRUCK
60		180			4	1	2	802052	2	EUROPEAN
63.5		178			4	7	9	903007	1	NISSAN-UD
65	143				4	1	1	K5-A634	2	GWB 190.50 SERIES
65		157			4	1	2	U-3180	1&3	VOITH
65		172			4	1	2	K5-A643	1	GWB 687.65 / 587.48 SERIES
65		172			4	1	2	K5-A643S	NON	GWB 687.65 / 587.48 SERIES
65		190			4	1	2	802036	1	SCANIA P600 SERIES
65		190			4	1	2	802036S	NON	SCANIA P600 SERIES
68	95				4	2	1	801001	1	MERCEDES
68	95				4	2	2	801001S	NON	MERCEDES NON LUBE
68	117				4	2	1	K5-A802	1	MERCEDES
68	117				4	2	1	K5-A802S	NON	MERCEDES - SEALED
68		166.5			4	1	2	968166	1	SINOTRUCK
71.43		223.04			4	7	3	5-54X	2	1900 SERIES - 4 BOLTS

UNIVERSAL JOINT DIMENSIONAL DATA

C	W1	W2	D2	D3	CAP QTY	CAP TYPE	FIG	PART NO.	LUBE	NOTES / APPLICATION
72		185			4	1	2	K5-A625	1	GWB 587.50 SERIES
72		185			4	1	2	KS-A625-4A	3	GWB 587.50 SERIES - 4PT LUBE IN CAP
74	129				4	2	1	K5-A707	1	GWB 292.50 SERIES
74	154				7	4	1	K5-A626	2	GWB 190.55 SERIES
74		180			4	1	2	U-3208	2	VOITH
74		217			4	1	2	K5-A708	1	GWB 587.55 SERIES
77.8		255.19			4	1	2	5-339X	2	1950 SERIES SPICER
83	129				4	2	1	K5-A714	1	GWB 390.60 SERIES
83	139				4	1	1	K5-A709	1	GWB 292.55 SERIES
83		220			4	1	2	U-3250	3	VOITH
83	175				4	1	1	K5-A627	2	GWB 190.60 SERIES
95	139				4	2	1	K5-A715	1	GWB 390.65 SERIES
95	160				4	1	1	5-372X	2	GWB 292.60 SERIES
95	190				4	1	1	K5-A628	2	GWB 190.65 SERIES
95		255.7			4	1	2	U-3285	1	VOITH
110	160				4	1	1	K5-A716	2	GWB 390.70 SERIES
110	176				4	1	1	K5-A711	1	GWB 292.65 SERIES
110	210				4	1	1	K5-A629	2	GWB 190.70 SERIES
110		275			4	1	2	U-3315	2	VOITH
120	176				4	1	1	K5-A717	1	GWB 390.75 SERIES
120	196				4	1	1	K5-A718	1	GWB 292.70 SERIES
120	235				4	1	1	K5-A712	2	GWB 190.75 SERIES
130	216				4	1	1	K5-A719	1	GWB 390.80 SERIES
130	216				4	1	1	K5-A790	1	GWB 292.75 SERIES
130	262				4	1	1	K5-A713	2	GWB 190.80 SERIES
154	250				4	1	1	K5-A820	1	GWB 292.80 SERIES
170	276				4	1	1	393-85	1	GWB 393.85 SERIES
			33.34	59.53	4	3T	4	114-2110	2&3	2C SERIES MECHANICS
			33.34	59.53	4	3D	4	114-2117	2	2C SERIES - WITH BOLTS
			33.34	59.53	4	3D	4	114-2186	3	2C SERIES -WITH OUT BOLTS
			33.34	59.53	2	3T	4	114-2116	2	2C SERIES MECHANICS
			33.34	59.53	2	3D				WITH BOLTS
			33.34	59.53	2	3T	4	114-2185	3	2C SERIES MECHANICS
			33.34	59.53	2	3D				WITH OUT BOLTS
			36.52	69.85	4	3T	4	114-3100	2	3C SERIES MECHANICS
			36.52	69.85	4	4	4	114-3125	2	3C SERIES MECHANICS
			36.52	69.85	2	3D	4	114-3101	2&3	3C SERIES MECHANICS
			36.52	69.85	2	3T				COUNTERSUNK

UNIVERSAL JOINT DIMENSIONAL DATA

C	W1	W2	D2	D3	CAP QTY	CAP TYPE	FIG	PART NO.	LUBE	NOTES / APPLICATION
			39.52	69.85	2	3T	4	114-3121	2	3C SERIES MECHANICS
			36.52	69.85	2	4				LWT TO HWD
			36.52	87.32	4	3T	4	114-4100	2	4C SERIES MECHANICS
			36.52	87.32	4	4	4	114-4113	2	4C SERIES MECHANICS
			36.52	87.32	2	3T	4	114-4110	2	4C SERIES MECHANICS
			36.52	87.32	2	4				STANDARD HOLES
			36.52	87.32	2	3T	4	RUJ-4003	2	4C SERIES MECHANICS
			36.52	87.32	2	3D	4			COUNTERSUNK
			36.52	87.32	2	3D	4	114-4141	2	4C SERIES MECHANICS
			36.52	87.32	2	4				
			36.52	87.32	4	3D	4	114-4105	2	4C SERIES MECHANICS COUNTERSUNK
			42.85	88.9	4	3T	4	114-5122	2	5C SERIES MECHANICS
			42.85	88.9	4	4	4	114-5177	2	5C SERIES MECHANICS
			42.85	88.9	4	4	4	114-5177P	2	5C SERIES MECHANICS - PREMIUM
			42.85	88.9	4	4	4	114-5177SP	NON	5C SERIES - NON LUBE
			42.85	88.9	4	3D	4	114-5148	2	5C SERIES MECHANICS
			42.85	88.9	2	3T	4	114-5173	2	5C SERIES MECHANICS
			42.85	88.9	2	4				
			42.85	88.9	2	3T	4	114-5031	NON	5C SERIES MECHANICS
			42.85	88.9	2	4				33.29MM HOLE IN CENTRE
			42.85	88.9	2	3T	4	114-5127	2	5C SERIES MECHANICS
			42.85	88.9	2	3D				
			42.85	114.3	4	3D	4	114-6104	2	6C SERIES - COUNTERSUNK
			42.85	114.3	4	4	4	114-6128	2	6C SERIES MECHANICS
			42.85	114.3	4	4	4	114-6128P	2	6C SERIES MECHANICS - PREMIUM
			42.85	114.3	4	4	4	114-6128SP	NON	6C SERIES - LUBE FOR LIFE
			42.85	114.3	4	3T	4	114-6143	2	6C SERIES MECHANICS
			42.85	114.3	4	3T	4	114-6143P	2	6C SERIES MECHANICS - PREMIUM
			42.85	114.3	2	3T	4	114-6114	2	6C SERIES MECHANICS
			42.85	114.3	2	4				
			42.85	114.3	2	3T	4	114-6103	2	6C SERIES MECHANICS
			42.85	114.3	2	3D				
			42.85	114.3	2	4	4	114-6285	2	6C SERIES MECHANICS
			42.85	114.3	2	4				DOUBLE KEYED
			42.85	114.3	2	3T	4	114-6162	2	6C SERIES MECHANICS TO
			49.21	117.6	2	3T				7C SERIES MECHANICS
			42.85	114.3	2	3T	4	114-6163	2	6C SERIES MECHANICS TO
			49.21	117.6	2	4				7C SERIES MECHANICS

UNIVERSAL JOINT DIMENSIONAL DATA

C	W1	W2	D2	D3	CAP QTY	CAP TYPE	FIG	PART NO.	LUBE	NOTES / APPLICATION
			49.2	104	4	4	4	804001	2	EUROPEAN TRACTOR
			49.21	107.5	4	3T	4	CP58WB-29	2	JOHN DEERE - SKIDDER
			49.21	107.5	4	3T	4	CP58WB-29P	2	JOHN DEERE - SKIDDER - PREMIUM
			49.21	107.5	2	3T	4	CP58WB-37	2	JOHN DEERE - SKIDDER
			49.21	107.5	2	4				
			49.21	107.5	4	4	4	CP58WB38	2	JOHN DEERE - SKIDDER
			49.21	117.6	4	3T	4	114-7205	2	7C SERIES MECHANICS
			49.21	117.6	4	4	4	114-7126	2	7C SERIES MECHANICS
			49.21	117.6	4	4	4	114-7126SP	NON	7C SERIES - NON LUBE
			49.21	117.6	4	4	4	114-7126P	2	7C SERIES MECHANICS PREMIUM
			49.21	117.6	4	4	4	114-7126-4A	3	7C SERIES - 4 POINT LUBE
			49.21	117.6	4	3D	4	114-7208	2	7C SERIES - COUNTERSUNK
			49.21	117.6	2	3T	4	114-7207	2	7C SERIES MECHANICS
			49.21	117.6	2	4				WING - BLOCK
			49.21	117.6	2	3D	4	114-7209	2	7C SERIES MECHANICS
			49.21	117.6	2	4				COUNTERSUNK
			49.21	117.6	2	3T	4	114-7206	2	7C SERIES MECHANICS
			49.21	117.6	2	3D				COUNTERSUNK
			49.21	174.63	4	3T	4	114-8205	2	8C SERIES MECHANICS
			49.21	174.63	4	3T	4	114-8205P	2	8C SERIES MECHANICS - PREMIUM
			49.21	174.63	4	3D	4	114-8208	2	8C SERIES MECHANICS
			49.21	174.63	4	4	4	114-8113	2	8C SERIES MECHANICS
			49.21	174.63	4	4	4	114-8113P	2	8C SERIES MECHANICS - PREMIUM
			49.21	174.63	4	4	4	114-8113SP	NON	8C SERIES - NON LUBE
			49.21	174.63	2	3T	4	114-8207	2	8C SERIES MECHANICS
			49.21	174.63	2	4				
			49.21	174.63	2	3T	4	114-8207-4A	2	8C SERIES MECHANICS
			49.21	174.63	2	4				4 POINT LUBE
			49.21	174.63	2	3T	4	114-8206	2	8C SERIES MECHANICS
			49.21	174.63	2	3D				COUNTERSUNK
			50	115	4	3T	4	904001	2	ISUZU
			56	140	4	3T	4	904002	1	ISUZU
			60	104	4	4	4	904003	1	FURUKAWA
			60	159	4	3	4	904004	1	ISUZU
			61.98	125.22	4	4	4	404001	2	J170 TWIN DISC
			71.44	123.83	4	3T	4	114-8514	2	8.5C SERIES MECHANICS
			71.44	123.83	4	4	4	114-8516	2	8.5C SERIES MECHANICS
			71.44	123.83	4	4	4	114-8516P	2	8.5C SERIES MECHANICS - PREMIUM

UNIVERSAL JOINT DIMENSIONAL DATA

C	W1	W2	D2	D3	CAP QTY	CAP TYPE	FIG	PART NO.	LUBE	NOTES / APPLICATION
			71.44	123.83	4	4	4	114-8516SP	NON	8.5C SERIES - NON LUBE
			71.44	123.83	2	3T	4	114-8508	1	8.5C SERIES MECHANICS
			71.44	168.3	4	3T	4	114-9014	2	9C SERIES MECHANICS
			71.44	168.3	4	3T	4	114-9014P	2	9C SERIES MECHANICS - PREMIUM
			71.44	168.3	4	3T	4	114-9014SP	NON	9C SERIES MECHANICS - SEALED
			71.44	168.3	4	4	4	114-9016	2	9C SERIES MECHANICS
			71.44	168.3	4	4	4	114-9016P	2	9C SERIES MECHANICS PREMIUM
			71.44	168.3	4	4	4	114-9016SP	NON	9C SERIES - NON LUBE
			71.44	168.3	2	3T	4	114-9017	2	9C SERIES MECHANICS
			71.44	168.3	2	4				WING - BLOCK
			71.44	168.3	2	3T	4	114-9017P	2	9C SERIES MECHANICS
			71.44	168.3	2	4				WING - BLOCK - PREMIUM
			71.44	168.3	2	3T	4	114-9026	2	9C SERIES MECHANICS
			71.44	168.3	2	3D				
			71.44	168.3	4	4	4	114-9500	1	J310 TWIN DISC
			71.44	168.3	4	4	4	114-9500SP	NON	J310 T.D - NON LUBE
			88.9	172.72	4	4	4	114-10500	2	J490 TWIN DISC - .625" BOLT
			88.9	172.72	2	4	4	114-10033	2	J490 TWIN DISC TO
			92.07	165.1	2	4				10C MECHANICS .625" BOLTS
			88.9	172.72	4	4	4	114-11002	2	J600 TWIN DISC .750" BOLTS
			92.07	165.1	4	3	4	114-10000	2	10C MECHANICS LWD
			92.07	165.1	4	4	4	114-10003	2	10C MECHANICS .562" BOLTS
			92.07	165.1	4	3D	4	114-10007	2	10C MECHANICS - COUNTERSUNK
			92.07	165.1	4	4	4	114-10011	2	10C MECHANICS .625" BOLTS
			92.07	165.1	4	4	4	114-10011P	2	10C MECHANICS .625" BOLTS PREMIUM
			92.07	165.1	4	4	4	114-10011SP	NON	10C MECH .625" BOLTS - NON LUBE
			92.2	241.3	4	3D	4	114-12000	2	12C MECHANICS .500" BOLTS
			92.2	241.3	4	4	4	114-12002	2	KOMATSU 14MM BOLTS
			92.2	241.3	4	4	4	114-12002SP	NON	KOMATSU 14MM BOLTS NON LUBE
			99.97	199.95	4	4	4	114-15002	2	J800 TWIN DISC
			99.97	199.95	4	4	4	114-15002SP	2	J800 T/DISC - NON LUBE
			99.97	199.95	4	4	4	114-15003	2	J800 T/DISC M20X2.5 BOLTS
			99.97	199.95	4	4	4	114-15003SP	2	J800 T/DISC - NON LUBE
			134.88	269.5	4	4	4	114-14000	2	14C SERIES MECHANICS

APPLICATION LISTING

Make	Model	Year	Joint Position			Notes
			Front	Middle	Rear	
AUSTIN						
1800	MANUAL	65-70	K5-A514		N/A	INNER HALF SHAFT
	AUTO	65-70	K5-L4R		N/A	INNER HALF SHAFT
TASMAN, KIMBERLEY		70-73	K5-A514		N/A	INNER HALF SHAFT
CHRYSLER						
CENTURA	KB,KC	75-78	RUJ-2038		RUJ-2038	6 CYL
VALIANT	AP5,AP6, VC MANUAL	62-69	114-67R		RUJ-2038	
	VC(AUTO), VE -CM	66-78	RUJ-2038		RUJ-2038	EXC CHARGER D74
	VJ, VK CHARGER	73-76	RUJ-2038		114-232	D74 & H/D AXLE (SURE GRIP)
DAIHATSU						
HI JET	S38,40,60,65,70	72-84	K5-A510		K5-A510	
	S75,85	84-90	RUJ-1500		RUJ-1500	
	S76 4WD	84-86	K5-A510		K5-A510	FRONT SHAFT
	S76 4WD	84-86	RUJ-1500		RUJ-1500	REAR SHAFT
DELTA	ALL	73-77	K5-A522		K5-A522	EXC SOME 3.0L MODELS(RUJ-2505)
	ALL	77-8/84	114-3105	114-3105	114-3105	
F SERIES	F10	74-3/75	K5- A522		K5-A522	
	ALL F SERIES & SCAT	4/75-85	RUJ-2023		RUJ-2023	
FEROZA 4WD	F300,F310	10/88-1/99	RUJ-1500		RUJ-1500	FRONT SHAFT
	F300,F310	10/88-1/99	K5-A522		K5-A522	REAR SHAFT
ROCKY 4WD	ALL MODELS	84-93	RUJ-2023		RUJ-2023	FRONT & REAR SHAFT (INT SNAP RING TYPE) SOME
			K5-A522		K5-A522	FRONT & REAR SHAFT (EXT CIRCLIP TYPE) MOST
	F78 SPORTS WAGON	9/93-1/99	K5-A522		K5-A522	
TERIOS 4WD	J100/J102 DX/ SX WAGON	97-				CRIMPED UNIVERSAL JOINTS
DAIMLER						
DOUBLE SIX	SERES 1,2,3	72-	K5-13XR	K5-13XR	K5-13XR	DRIVE SHAFT
			K5-GB10R		K5-GB10R	HALF SHAFT
SOVEREIGN	SERIES 1,2,3	68-86	K5-13XR	K5-13XR	K5-13XR	DRIVE SHAFT
			K5-GB10R		K5-GB10R	HALF SHAFT
		86-	K5-L4R	K5-L4R	K5-L4R	DRIVE SHAFT

APPLICATION LISTING

Make	Model	Year	Joint Position			Notes
			Front	Middle	Rear	
FIAT						
124,125, 131, 132		68-82	K5-LGB80R		K5-LGB80R	
130		72-76	K5-L4R		K5-L4R	
FORD						
CAPRI	4 CYL IMPORTED PROD	69-73	K5-GB150	K5-GB150	K5-GB150	EXTERNAL CIRCLIP TYPE
	4 CYL AUST BUILT	71-73	RUJ-1786	RUJ-1786	RUJ-1786	INTERNAL SNAP RING TYPE
	V6 IMPORTED	69-	902011		902011	VEHICLES HAVE STAKED JOINTS - REF TO NOTE END OF SECTION
	V6 AUST BUILT	71-	RUJ-1786	RUJ-1786	RUJ-1786	INTERNAL SNAP RING TYPE
CORTINA	MK 1, 2	62-71	K5-GB150		K5-GB150	EXTERNAL CIRCLIP TYPE
	MK 1, 2	62-71				VEHICLES HAVE STAKED JOINTS - REF TO NOTE END OF SECTION
	MK 1, 2 AUST BUILT	69-71	RUJ-1786		RUJ-1786	INTERNAL SNAP RING TYPE
	TC,TD,TE, TF 4 CYL ALL	71-82	RUJ-1786	RUJ-1786	RUJ-1786	
	TC,TD,TE, TF 6 CYL ALL	71-82	RUJ-1786		RUJ-1786	
ESCORT	MK1 1100,1300, 1558 T/CAM	66-3/70	K5-GB150		K5-GB150	
	MK 1 1100	4/70-	RUJ-1786		RUJ-1786	
	MK 1 1300	4/70-75	RUJ-1786	RUJ-1786	RUJ-1786	
	MK 1, 2 SOME	66-81				VEHICLES HAVE STAKED JOINTS - REF TO NOTE END OF SECTION
	MK 2 1300, 1600, 2000	75-81	RUJ-1786	RUJ-1786	RUJ-1786	1 AND * 2 PIECE SHAFTS
FAIRLANE (6 CYL)	ZA,ZB	67-69	RUJ-2038		RUJ-2039	USE RUJ-2039 WITH 9", USE RUJ-2038 FOR BORG WARNER
	ZC	69-70	RUJ-2038		RUJ-2029	USE RUJ-2039 WITH 9", USE RUJ-2038 FOR BORG WARNER
	ZD-NA	71-5/91	RUJ-2038		RUJ-2038	
	NC	6/91-95	RUJ-2038		RUJ-2038	STEEL SHAFTS
	NC-AU	6/91-02	K5-13XR		K5-13XR	ALUMINIUM SHAFTS
FAIRLANE (V8)	ZA, ZB	67-69	RUJ-2038		RUJ-2039	9"
	ZC 302 3SPD MAN	69-70	RUJ-2038		RUJ-2029	9"
	ZC, ZD, ZF,ZG 351 FMX AUTO	69-76	RUJ-2038		RUJ-2039	9"
	ZD ,ZF, ZG 302	70-76	RUJ-2038		RUJ-2038	BORG WARNER
	ZH 4.9L	76-79	RUJ-2038		RUJ-2038	
	ZH 5.8L	76-79	RUJ-2038		RUJ-2029	INTERNAL SNAP RINGS - 9"
	ZJ, ZK	79-84	RUJ-2038		RUJ-2038	

APPLICATION LISTING

Make	Model	Year	Joint Position			Notes
			Front	Middle	Rear	
FORD continued						
FAIRLANE (V8) continued	NC	6-91-95	RUJ-2038		RUJ-2038	STEEL SHAFTS
	NC-AU	6/91-02	K5-13XR		K5-13XR	ALUMINIUM SHAFTS
FALCON (6 CYL)	XK-XR	60-67	RUJ-1786		RUJ-1786	
	XR,XT (TAXI H/D MODEL)	67-68	K5-13XR		RUJ-2039	
	XT,XW 188 CU. IN	68-69	RUJ-1786		RUJ-1786	
	XW	69-70	RUJ-2038		RUJ-2029	9"
	XY-XC WITH DRUM BRAKES	70-79	RUJ-2038		RUJ-2038	
	XC WITH DISC REAR BRAKES	76-79	RUJ-2038		RUJ-2029	9"
	XD,XE,XF	79-88	RUJ-2038		RUJ-2038	
	XG UTE,VAN	93-96	K5-13XR		K5-13XR	
	XG -XH UTE, VAN	93-99	K5-13XR		K5-13XR	
	EA MAN & 3SPD AUTO	88-6/91	RUJ-2038		RUJ-2038	INTERNAL SNAP RINGS
	EA AUTO SED &MPFI WAGON	88-6/91	K5-13XR		K5-13XR	EXTERNAL SNAP RINGS
	EA WAGON 4SPD AUTO TBFI	88-6/91	K5-13XR			
	EB,ED,EF,EL AU, AU2,AU3	7/91-10/02	K5-13XR		K5-13XR	STEEL & ALUMINIUM SHAFTS
	BA SEDAN ALL 6 CYL (EXCEPT TURBO)	11/02-		K5-13XR	CV-860	* RUBBER COUPLING FRONT
	BA MKII,BF SEDAN ALL 6 CYL (EXCEPT TURBO)	10/04-		K5-13XR	CV-860	* RUBBER COUPLING FRONT
	BA MKII,BF SEDAN ALL 6 CYL (EXCEPT TURBO)	11/02-		K5-13XR	CV-860	* RUBBER COUPLING FRONT
FALCON (6 CYL)	BA,BF SEDAN 6CYL TURBO W/OUT U/ JOINT	11/02-		CV-862	CV-861	* RUBBER COUPLING FRONT
FALCON (V8)	XR, XT, XW INC GT	66-69	K5-13XR		RUJ-2039	9"
	XW, XY GTHO	69-71	RUJ-3002		RUJ-3000	9"
	XY, XA, XB 302	70-76	RUJ-2038		RUJ-2038	
	XA, XB 302	72-76	RUJ-2038		RUJ-2029	WITH 9" DIFF EXC GT351
	XA, XB 351 INC GT	72-76	K5-13XR		RUJ-2039	
	XA, XB 351GT WITH H/D SHAFT	72-76	RUJ-3002		RUJ-3000	
	XC SEDAN	76-79	RUJ-2038		RUJ-2038	DRUM REAR B/W DIFF
	XC SEDAN	76-79	RUJ-2038		RUJ-2029	DISC BRAKE B/W DIFF
	BA, BF V8 SEDAN WITHOUT U/JOINT	11/02-	CV-862		CV-861	* RUBBER COUPLING FRONT

APPLICATION LISTING

Make	Model	Year	Joint Position			Notes
			Front	Middle	Rear	
FORD continued						
FALCON (V8) continued	XC 351 WAGON, UTE, VAN	76-79	K5-13XR		RUJ-2039	
	XD, XE	79-84	RUJ-2038		RUJ-2038	
	EB	7/91-93	RUJ-2038		RUJ-2038	(SOME) INTERNAL SNAP RINGS
	EB, ED, EF, EL, AU, AU2, AU3	7/91-10/02	K5-13XR		K5-13XR	
	BA,BF V8 WAGON, UTE ALL	11/02-	K5-13XR		K5-13XR	
	LTD P5 LTD /LAN- DAU	73-76	K5-13XR		RUJ-2039	
	P6 LTD	76/79	RUJ-2038		RUJ-2029	
	FC,FD,FE	5/79-5/88	RUJ-2038		RUJ-2038	
	DC, DF(SOME)	6/88-7/91	RUJ-2038		RUJ-2038	STEEL TAILSHAFT INTERNAL SNAP RINGS
FALCON (V8)	DF,DL,AU	8/91-03	K5-13XR		K5-13XR	ALUMINIUM TAILSHAFT AND/OR EXTERNAL SNAP RINGS
BRONCO	F100, F150	ALL				
** F250, F350NOTE: RANGE OF JOINTS USED REQUIRES THAT ALL APPLICATIONS SHOULD BE MEASURED TO ENSURE CORRECT FITMENT OF EACH JOINT						
COURIER	2WD VC,MA, 2.0L, 2.2L	78-98	RUJ-2023	RUJ-2023	RUJ-2023	SOME VEHICLES HAVE STAKED JOINTS - REF TO NOTE END OF SECTION
	PE, PG, 2.6L & 2.5DT	02/99-8/04	K5-13XR	K5-13XR	K5-13XR	
	PH, 2.6L & 2.5DT	9/04-10/06	K5-13XR	K5-13XR	K5-13XR	
	4X4, PC, PD	87-98	RUJ-2049		RUJ-2049	FRONT SHAFT
		87-98	RUJ-2023	RUJ-2023	RUJ-2023	REAR SHAFT
COURIER	4X4, PE, PG	99-8/04				FRONT SHAFT
		99-8/04	K5-13XR	K5-13XR	K5-13XR	REAR SHAFT
						SOME VEHICLES HAVE STAKED JOINTS - REF TO NOTE END OF SECTION
	4X4, PH, 2.6L & 2.5DT	9/04-10/06	K5-13XR		K5-13XR	FRONT SHAFT
		9/04-10/06	RUJ-3002	RUJ-3002	RUJ-3002	REAR SHAFT
		9/04-10/06	K5-13XR		CV JOINT	FRONT SHAFT (CV JOINT NOT CURRENTLY SERVICEABLE)
		9/04-10/06	CV JOINT	CV JOINT	CV JOINT	REAR SHAFT (FITTED WITH THREE CV JOINTS - NOT CURRENTLY SERVICEABLE)
ECONOVAN (SPECTRON)	EASYLOADER	79-88				DUAL REAR WHEELS
	DIESEL E2200	83-	RUJ-2049		RUJ-2049	SINGLE REAR WHEELS
						SOME VEHICLES HAVE STAKED JOINTS -REF TO NOTE END OF SECTION
	MAXI	85-	RUJ-2023		RUJ-2023	

APPLICATION LISTING

Make	Model	Year	Joint Position			Notes
			Front	Middle	Rear	
FORD continued						
ECONOVAN (SPECTRON)	SPECTRON 4X4	85-88	RUJ-2049		RUJ-2049	FRONT SHAFT
	SPECTRON 4X4	85-88	RUJ-2023		RUJ-2023	REAR SHAFT
EXPLORER	4X4 WAGON	96-	K5-13XR		K5-13XR	FRONT SHAFT W/ SPORT TRAC
		96-	RUJ-3002		RUJ-3002	REAR SHAFT
		02-	K5-13XR		CV-860	FRONT SHAFT
RAIDER	4X4	91-	RUJ-2049		RUJ-2049	FRONT SHAFT
		91-	RUJ-2023	RUJ-2023	RUJ-2023	REAR SHAFT
RANGER	2WD,PJ 2.5DT	11/06-	RUJ-3002	RUJ-3002	RUJ-3002	
	4WD, PJ 3.0DT	11/06-	K5-13XR		K5-13XR	FRONT SHAFT
		11/06-	RUJ-3002	RUJ-3002	RUJ-3002	REAR SHAFT
TRANSIT	V21,V22,V24,V33 - 4CYL MAN	65-74	K5-L4R		K5-L4R	
	V21,V22,V24,V33,V51,V54,V65 - 4CYL AUTO	68-74	K5-13XR		K5-13XR	
	V51,V54,V65 - 4CYL MAN	65-74	K5-13XR		K5-13XR	
	V21,V23,V33,V51 (AUST PROD)	78-92	RUJ-2038		RUJ-2038	
	V24,V51,V54 (AUST PROD) LWB	78-82	RUJ-2030	RUJ-2030	RUJ-2038	SINGLE & DUAL REAR WHEELS
	NEW TRANSITS	94-		CV-855		(SOME) 94MM DIAMETER CV JOINT (BOOT KIT INCLUDED)
		94-		86-H288		(SOME) 108MM DIAMETER CV JOINT
		01-				(SOME) *RUBBER COUPLING FRONT
MAVERICK	DA 4X4	87-92	RUJ-2028		RUJ-2028	FRONT SHAFT
		87-92	901003		901003	REAR SHAFT
** SOME VEHICLES HAVE STAKED JOINTS (UNSERVICABLE WITHOUT SPECIAL TOOLING) REFER BEATTYS GROUP SHAFT REPLACEMENT OPTIONS						
HOLDEN / ISUZU						
EARLY MODELS (6 CYL)	FX-FJ	48-56	RUJ-1786		RUJ-1764	
	FB,FC,FE,EK,EJ	56-63	RUJ-1786		RUJ-1758	
	EH,HD,HR	63-67	RUJ-1786		RUJ-1786	
	HK - 6 Cylinder	68-69	RUJ-1786		RUJ-2030	WITH 4SPD MAN & 3.08 RATIO REAR AXLE ONLY
	HK,HT,HG,HQ,HJ,HX, HZ - 6 Cylinder	68-80	RUJ-1786		RUJ-1786	
	HJ,HX,HZ - V8	74-80	RUJ-2030		RUJ-2030	WITH SALISBURY DIFF
	WB	80-85	RUJ-2030		RUJ-2030	UTE, PANEL VAN

APPLICATION LISTING

Make	Model	Year	Joint Position			Notes
			Front	Middle	Rear	
HOLDEN / ISUZU continued						
EARLY MODELS (6 CYL) continued	HQ ONE TONNER (SOME)	71-73	RUJ-2030		RUJ-2030	SOME
	HQ-WB ONE TONNER	71-85	RUJ-2500R		RUJ-2500R	
EARLY MODELS (V8)	HK 307	68-69	RUJ-1786		RUJ-1786	MANUAL
	HK, HT 307	68-70	RUJ-2030		RUJ-2030	AUTO & BANJO DIFF
	HK, HT 307	68-70	RUJ-2030		RUJ-2032	AUTO & SALISBURY DIFF,ALL 327
	HT, HG 253	69-71	RUJ-2030		RUJ-2030	MAN & AUTO
	HT 308	69-70	RUJ-2500R		RUJ-2502	MAN
	HG 308	70-71	RUJ-2030		RUJ-2030	WITH BANJO DIFF
					RUJ-2032	WITH SALISBURY DIFF
	HG 350	70-71	RUJ-2030		RUJ-2502	MANUAL
	HG 350	70-71	RUJ-2030		RUJ-2032	AUTO
	HQ 253,308	71-74	RUJ-2030		RUJ-2030	
	HQ 350	71-74	RUJ-2500R		RUJ-2500R	
	HJ,HX,HZ 253 & 308	74-80	RUJ-2030		RUJ-2030	253 ALL ,308 MAN & AUTO EXCEPT TURBO 400
	HJ, HX HZ 308	74-80	RUJ-2500R		RUJ-2030	308 WITH TURBO 400 AUTO
	WB EXCEPT ONE TONNER	80-85	RUJ-2030		RUJ-2030	
	HQ-WB ONE TONNER	71-85	RUJ-2500R		RUJ-2500R	
COMMODORE (4 CYL)	VC, VH	80-83	RUJ-1786	CV-856	RUJ-1786	
COMMODORE (6 CYL)	VB,VC,VH	78-84	RUJ-1786	CV-856	RUJ-1786	EXCEPT WITH HEAVY DUTY REAR AXLE
	VB,VC,VH	78-84	RUJ-2030	CV-855	RUJ-2030	WITH HEAVY DUTY REAR AXLE
	VK	84-86	RUJ-1786	CV-856	RUJ-1786	EXCLUDES EFI MODELS
	VK EFI, VL	84-88	RUJ-2030	CV-855	RUJ-2030	INCLUDES VL TURBO
	VN,VP,VR,VS & VT AUTO	88-98	RUJ-2038	CV-855	RUJ-2038	
	VT MAN	96-9/00		CV-855	RUJ-2038	FRONT HAS RUBBER DRIVE COUPLING (DONUT)
	VX,VY,VZ,VE MAN	10/00-		STAKED		FRONT & REAR RUBBER DRIVE COUPLINGS
	VX,VY,VZ,VE AUTO	10/00-		STAKED		FRONT & REAR RUBBER DRIVE COUPLINGS
	VX,VY,VZ AUTO SUPERCHARGED V6	10/00-		STAKED		FRONT & REAR RUBBER DRIVE COUPLINGS
**ALL VX, VY, VZ, VE'S HAVE STAKED MIDDLE JOINTS (UNSERVICEABLE WITHOUT STAKING TOOLING) REFER BEATTYS GROUP FOR SHAFT REPLACEMENT OPTIONS						
COMMODORE (V8)	VB,VC,VH,	78-84	RUJ-2030	CV855	RUJ-2030	253 ALL, 308 MAN AND AUTO EXCEPT TURBO 400
	VB,VC,VH 308 TURBO 400 ONLY	78-84	RUJ-2500R	CV855	RUJ-2030	

APPLICATION LISTING

Make	Model	Year	Joint Position			Notes
			Front	Middle	Rear	
HOLDEN / ISUZU continued						
COMMODORE (V8) continued	VK,VL	84-88	RUJ-2030	CV855	RUJ-2030	
	VP,VR,VS & VT AUTO	88-9/00	RUJ-2038	CV855	RUJ-2038	
	VT SRIES 1 V8 MANUAL	9/97-9/00		CV855	RUJ-2038	FRONT HAS RUBBER DRIVE COUPLING (DONUT)
	VT SERIES 2 5.7L GEN 3 (HI PERF) MAN	98-9/00		CV855	RUJ-2038	FRONT HAS RUBBER DRIVE COUPLING (DONUT)
	VX,VY,VZ	10/00-		STAKED		FRONT & REAR RUBBER DRIVE COUPLINGS
	VE	10/06-		STAKED		FRONT & REAR RUBBER DRIVE COUPLINGS
**ALL VX, VY, VZ, VE'S HAVE STAKED MIDDLE JOINTS (UNSERVICEABLE WITHOUT STAKING TOOLING) REFER BEATTYS GROUP FOR SHAFT REPLACEMENT OPTIONS						
DROVER QG	QG	85-87	RUJ-1795		RUJ-1795	IF INTERNAL CIRCLIPS
	QG	85-87	RUJ-1783		RUJ-1783	IF EXTERNAL CIRCLIPS
FRONTERA	2.0L 2 DOOR	96-	K5-L4R		K5-L4R	FRONT & REAR SHAFTS
GEMINI	TC,TD,TE,TFTG, TX PETROL	75-	RUJ-1786		RUJ-1786	DIESEL GEMINIS HAVE STAKED JOINTS - REF TO NOTE END OF SECTION
JACKEROO / BIGHORN	UBS	81-7/88	K5-LGB80R		RUJ-2033	FRONT SHAFT
			RUJ-2033	RUJ-2033	RUJ-2033	REAR SHAFT
				(LWB ONLY)		
	UBS	8/88-5/98	RUJ-2033		RUJ-2033	FRONT SHAFT
		8/88-5/98	RUJ-2033	RUJ-2033	RUJ-2033	REAR SHAFT
				(LWB ONLY)		
	UVS 3.5L V6 AND TURBO DIESEL	6/98-	901013		901013	FRONT SHAFT
			901013	901013	901013	REAR SHAFT
	UVS MONTEREY (WITH TORQUE DEMAND ONLY)	6/98-	RUJ-2033		RUJ-2033	FRONT SHAFT
	UVS MONTEREY (WITH TORQUE DEMAND ONLY)	6/98-	RUJ-2033	RUJ-2033	RUJ-2033	REAR SHAFT
PIAZZA 2.0L TURBO	2.0L TURBO	86-88	STAKED		STAKED	VEHICLES HAVE STAKED JOINTS - REF TO NOTE END OF SECTION
RODEO 2WD	KB, KBD 20 SERIES	75-88	K5-LGB80R	K5-LGB80R	K5-LGB80R	
	TF SERIES	8/88-	RUJ-2033	RUJ-2033	RUJ-2033	
	TF R9 3.2 V6	6/98 2003	901013	RUJ-2033	RUJ-2033	
RODEO 4WD	KB, KBD 20 SERIES	79-7/88	K5-LGB80R		RUJ-2033	FRONT SHAFT
	KB, KBD 20 SERIES	79-7/88	RUJ-2033	RUJ-2033	RUJ-2033	REAR SHAFT
	TF SERIES	8/88-	RUJ-2033		RUJ-2033	FRONT SHAFT - RUJ-2033 IA NON LUBE USED IN SOME VEHICLES

APPLICATION LISTING

Make	Model	Year	Joint Position			Notes
			Front	Middle	Rear	
HOLDEN / ISUZU continued						
RODEO 4WD		8/88-	RUJ-2033	RUJ-2033	RUJ-2033	"REAR SHAFT - RUJ-2033 IA NON LUBE USED IN SOME VEHICLES "
	TF R9 3.2 V6, TURBO DIESEL	6/98 -2003	RUJ-2033		RUJ-2033	FRONT SHAFT
		6/98 -2003	RUJ-2033	RUJ-2033	RUJ-2033	REAR SHAFT
	RA TURBO DIESEL	2003-	901013	901013	901013	REAR SHAFT
SCURRY		85-87	RUJ-1501		RUJ-1501	
SHUTTLE	WFR11, WFR51	82-86	K5-LGB80R		K5-LGB80R	IF EXTERNAL CIRCLIPS
		82-90	RUJ-2033		RUJ-2033	IF INTERNAL SNAP RINGS
STATESMAN	HQ 308 V8	71-74	RUJ-2030		RUJ-2030	
	HQ 350 V8	71-74	RUJ-2500R		RUJ-2030	
	HJ, HX, HZ	74-79	RUJ-2500R		RUJ-2030	
	WB	80-85	RUJ-2030		RUJ-2030	
	VQ, VR, VS STATESMAN/CAPRICE	90-6/99	RUJ-2038	CV-855	RUJ-2038	
	WH SERIES 1 STATESMAN/CAPRICE	7/99-8/01	RUJ-2038	CV-855	RUJ-2038	
	WH SERIES 2, WK STATESMAN/CAPRICE V6 MPFI, WM	9/01-		STAKED		FRONT & REAR RUBBER DRIVE COUPLINGS
	WH SERIES 2, WK STATESMAN/CAPRICE V6 S/C, V8	9/01-		STAKED		FRONT & REAR RUBBER DRIVE COUPLINGS
	WM V8	9/06-		STAKED		WH-WM SERIES 2, WK'S HAVE STAKED MIDDLE JOINTS REF END OF SECTION
SUBURBAN	K8 V8 DIESEL TURBO	98-01	5-178X		5-178X	
	K8 5.7L V8 PETROL	98-01	RUJ-3002		RUJ-3000	
TORANA (4 CYL)	HB	67-69	K5-LGB80R		K5-LGB80R	IF EXTERNAL CIRCLIPS
		67-69	RUJ-1786		RUJ-1786	IF INTERNAL SNAP RINGS
	LC, LJ, TA, LH, LX, UC (SUNBIRD)	70-80	RUJ-1786		RUJ-1786	
TORANA (6 CYL)	LC, LJ, LH, LX, UC	70-80	RUJ-1786		RUJ-1786	
TORANA (V8)	LH, LX,	74-78	RUJ-2030		RUJ-2030	
** SOME VEHICLES HAVE STAKED JOINTS (UNSERVICEABLE WITHOUT SPECIAL TOOLING) REFER BEATTYS GROUP SHAFT REPLACEMENT OPTIONS						
HYUNDAI						
SANTA FE V6	SOME MODELS				902026	IF EXTERNAL CIRCLIPS
SANTA FE V6	CAN HAVE				STAKED	UNSERVICEABLE WITHOUT SPECIAL TOOLING

APPLICATION LISTING

Make	Model	Year	Joint Position			Notes
			Front	Middle	Rear	
HYUNDAI continued						
TUCSON	SOME MODELS				K5-13XR	IF EXTERNAL CIRCLIPS
	SOME MODELS				RUJ-2049	IF INTERNAL SNAP RINGS
	CAN HAVE				STAKED	UNSERVICEABLE WITHOUT SPECIAL TOOLING
JAGUAR						
XJ6, XJ12, XJS		68-86	K5-13XR	K5-13XR	K5-13XR	
		87-	K5-L4R	K5-L4R	K5-L4R	
		ALL	K5-GB10R			HALF SHAFT REAR
JEEP						
J10,J20 4X4		74-88	K5-13XR		K5-13XR	FRONT & REAR SHAFTS
			5-297X			WHEEL JOINTS FRONT AXLE
CHEROKEE	INCLUDING GRAND CHEROKEE	88-98	K5-13XR		K5-13XR	FRONT & REAR SHAFTS
			5-297X			WHEEL JOINTS FRONT AXLE W/OUT ANTI LOCK BRAKES
			5-297X			WHEEL JOINTS FRONT AXLE WITH ANTI LOCK BRAKES
WRANGLER	CJ,YJ	94-	K5-13XR		K5-13XR	FRONT & REAR SHAFTS
			5-260X			WHEEL JOINTS FRONT AXLE
KIA						
SPORTAGE	4 X 4	11/96-	RUJ-2049		RUJ-2049	FRONT AND REAR SHAFT
LADA						
NIVA	4 X 4 WAGON (MOST 23.8MM CAP)	83-92	K5-LGB80R		K5-LGB80R	FRONT AND REAR SHAFT
	4 X 4 WAGON (SOME 28MM CAP)	88-92	802005		802005	FRONT AND REAR SHAFT
	4 X 4 WAGON	92-99	802005		802005	FRONT AND REAR SHAFT
LEYLAND/MORRIS						
MINI 850,1100, COOPER	AUTO	59-78	K5-GB150			INNER FWD SHAFT
	COOPER S FROM BODY 1918		K5-GB150			INNER FWD SHAFT
NOMAD	1300, 1500	69-72	114-2101			INNER FWD SHAFT MANUAL
NOMAD		69-72	RUJ-1786			INNER FWD SHAFT AUTO
MARINA	4 CYL	72-75	K5-GB150		K5-GB150	
	6 CYL	72-75	RUJ-1786		RUJ-1786	

APPLICATION LISTING

Make	Model	Year	Joint Position			Notes
			Front	Middle	Rear	
LEYLAND/MORRIS continued						
P76	6 CYL	72-75	RUJ-1786		RUJ-1786	3 SPEED MANUAL, AUTO
	6 CYL	73-75	RUJ-2030		RUJ-2030	4 SPEED MANUAL
	V8	73-75	RUJ-2030		RUJ-2038	
MG	MGB, MGB GT	62-81	K5-LGB80R		K5-LGB80R	
	MGC, MGC GT, MGC V8	67-76	K5-13XR		K5-13XR	
MAZDA						
1200, 1300		67-77	RUJ-1784		RUJ-1784	
1500, 1800		67-74	RUJ-1784		RUJ-1784	
1600, CAPELLA		70-78	RUJ-1784	RUJ-1784	RUJ-1784	ONLY SOME - RUJ-1784
121, 121L		76-80	RUJ-1784	RUJ-1784	RUJ-1784	
323	RWD	77-85	RUJ-1500		RUJ-1500	
			RUJ-1784	RUJ-1784	RUJ-1784	SOME MODELS
626	CB2	78-83	RUJ-1784	RUJ-1784	RUJ-1784	
808, SAVANNA		72-77	RUJ-1784		RUJ-1784	
929, 929L	LA2-LA4	74-84	RUJ-1784	RUJ-1784	RUJ-1784	
	HB,HBES	84-87	STAKED	STAKED	STAKED	VEHICLES HAVE STAKED JOINTS -REF TO NOTE END OF SECTION
	HC, HD-E	87-97	STAKED	STAKED	STAKED	VEHICLES HAVE STAKED JOINTS -REF TO NOTE END OF SECTION
BONGO	VAN	68-78			RUJ-2023	HALF SHAFTS
MPV	3.0L V6	4/96-	STAKED	STAKED	STAKED	VEHICLES HAVE STAKED JOINTS -REF TO NOTE END OF SECTION
MX-5		89-	STAKED		STAKED	VEHICLES HAVE STAKED JOINTS -REF TO NOTE END OF SECTION
R100, RX-2, RX-3		67-73	RUJ-1784	RUJ-1784	RUJ-1784	SOME
RX4		74-78	RUJ-2049	RUJ-2049	RUJ-2049	
RX-5		78-82	RUJ-2049	RUJ-2049	RUJ-2049	

APPLICATION LISTING

Make	Model	Year	Joint Position			Notes
			Front	Middle	Rear	
MAZDA continued						
RX-7	SERIES 1	78-82	RUJ-1784		RUJ-1784	
	SERIES 2,3	82-85	STAKED		STAKED	SOME VEHICLES HAVE STAKED JOINTS - REF TO NOTE END OF SECTION
	SERIES 4,5,6	86-99	STAKED		STAKED	SOME VEHICLES HAVE STAKED JOINTS - REF TO NOTE END OF SECTION
RX-8		03-	STAKED		STAKED	
B SERIES UTES	B1600, B1800 2WD	71-82	RUJ-2023	RUJ-2023	RUJ-2023	
	B2000 2WD	82-6/88	RUJ-2023	RUJ-2023	RUJ-2023	
	B2000 2WD	6/85-12/86	RUJ-2023	RUJ-2023	RUJ-2023	
	B2000 2WD	1/87-10/91	RUJ-2023	RUJ-2023	RUJ-2023	SOME MAY HAVE STAKED JOINTS IN FRONT AND REAR
						SOME VEHICLES HAVE STAKED JOINTS - REF TO NOTE END OF SECTION
	B2600 4X4	3/87-10/91	RUJ-2049		RUJ-2049	FRONT SHAFT
		3/87-10/91	RUJ-2023	RUJ-2023	RUJ-2023	REAR SHAFT
						SOME HAVE STAKED JOINTS IN REAR SHAFT -REF TO NOTE END OF SECTION
BRAVO / BOUNTY	B2200,B2500, B2600 2WD	11/91-98	RUJ-2023	RUJ-2023	RUJ-2023	VEHICLES HAVE STAKED JOINTS -REF TO NOTE END OF SECTION
	B2500, B2600	2/99-8/04	K5-13XR	K5-13XR	K5-13XR	
	B2500, B2600	9/04-10/06	K5-13XR	K5-13XR	K5-13XR	
	B2500, B2600 4X4	11/91-98	RUJ-2049		RUJ-2049	FRONT SHAFT
		11/91-98	RUJ-2023	RUJ-2023	RUJ-2023	REAR SHAFT
		99-8/04	RUJ-2049		RUJ-2049	FRONT SHAFT
		99-8/04	K5-13XR	K5-13XR	K5-13XR	REAR SHAFT
	B2500, 4X4	9/04-10/06	K5-13XR		K5-13XR	FRONT SHAFT
	B2500, 4X4	9/04-10/06	RUJ-3002	RUJ-3002	RUJ-3002	REAR SHAFT
	B4000, 4X4		K5-13XR		CV JOINT	FRONT SHAFT (CV JOINT NOT CURRENTLY SERVICEABLE)
			CV JOINT	CV JOINT	CV JOINT	REAR SHAFT (FITTED WITH THREE CV JOINTS - NOT CURRENTLY SERVICEABLE)
BT-50	2.5DT, 3.0DT 2WD	11/06-	RUJ-3002	RUJ-3002	RUJ-3002	
	3.0DT 4X4	11/06-	K5-13XR		K5-13XR	FRONT SHAFT
		11/06-	RUJ-3002	RUJ-3002	RUJ-3002	REAR SHAFT
E SERIES VANS	E1300,E1400,E1600, E1800,E2200	71-12/83	RUJ-1784		RUJ-1784	INTERNAL CIRCLIPS
E SERIES VANS continued	E2200	84-	RUJ-2049		RUJ-2049	INTERNAL CLIPS
						SOME VEHICLES HAVE STAKED JOINTS -REF TO NOTE END OF SECTION

APPLICATION LISTING

Make	Model	Year	Joint Position			Notes
			Front	Middle	Rear	
MAZDA continued						
	E2000	84-	STAKED		STAKED	WITH DUAL REAR WHEELS
		84-	STAKED		STAKED	WITH SINGLE REAR WHEELS
						SOME VEHICLES HAVE STAKED JOINTS -REF TO NOTE END OF SECTION
TRIBUTE	AWD V6		K5-13XR		K5-13XR	
T SERIES TRUCKS	T2000	5/81-12/82	RUJ-3003	RUJ-3003	RUJ-3003	
	T2600	4/85-12/88	RUJ-3003	RUJ-3003	RUJ-3003	
	T3000	6/81-10/84	RUJ-3003	RUJ-3003	RUJ-3003	
	T3500	9/87-4/97	RUJ-3003	RUJ-3003	RUJ-3003	
	T4000	11/89-6/00	RUJ-4009	RUJ-4009	RUJ-4009	
	T4100	6/81-9/89	RUJ-4009	RUJ-4009	RUJ-4009	
	T4600	6/92-	RUJ-4009	RUJ-4009	RUJ-4009	
SOME VEHICLES HAVE STAKED JOINTS IN REAR SHAFT (UNSERVICEABLE WITHOUT SPECIAL TOOLING) REFER BEATTYS GROUP						
MITSUBISHI						
GALANT	GA	8/71-10/72	RUJ-1783		RUJ-1783	UP TO CF15
	GA, GB, GC, GD	11/72-12/77	RUJ-1786		RUJ-1786	GA (CF16 ON) GC, GD EXCEPT HARDTOP
	GC, GD	7/74-12/77	RUJ-1783		RUJ-1783	HARDTOP
LANCER	LA, LB, LC	9/74-8/81	RUJ-1783		RUJ-1783	
L200 EXPRESS UTE	MA, MB, MC, MD 1/2 TONNE 2WD	3/80-10/86	RUJ-1783	RUJ-1783	RUJ-1783	
	MA, MB, MC, MD 1 TONNE 2WD	3/80-10/86	RUJ-2045	RUJ-2045	RUJ-2045	
	MA, MB, MC, MD 4WD	6/81-10/86	RUJ-1783		RUJ-1783	FRONT SHAFT
		6/81-10/86	RUJ-2045		RUJ-2045	REAR SHAFT
L300 EXPRESS VAN & STAR WAGON	SA-SE 2WD	4/80-9/86	RUJ-1783		RUJ-1783	
	SC-WA 4WD	5/83-	RUJ-1783		RUJ-1783	FRONT SHAFT
	SC-WA 4WD	5/83-	RUJ-2045		RUJ-1783	REAR SHAFT
	SF-WA 2WD 2.0L	10/86-	RUJ-1783		RUJ-1783	
	SF-WA 2WD 2.4L PET, 2.5L DIESEL	10/86-	RUJ-2045		RUJ-2045	
PAJERO	NA, NG	1983-90	RUJ-1783		RUJ-1783	EXC LWB - V6 FRONT SHAFT
	NA, NG	1983-90	RUJ-2045		RUJ-2045	EXC LWB - V6 REAR SHAFT
	ND, NG	1986-91	RUJ-1783		RUJ-1783	LWB V6 ONLY FRONT SHAFT
	ND, NG	1986-91	RUJ-3006		RUJ-3006	LWB V6 ONLY REAR SHAFT
	NH, NJ	5/91-97	RUJ-1783		RUJ-1783	FRONT SHAFT
	NH, NJ	5/91-97	RUJ-3006		RUJ-3006	REAR SHAFT
	NK, NM	11/96-11/02	RUJ-1783		RUJ-1783	FRONT SHAFT

APPLICATION LISTING

Make	Model	Year	Joint Position			Notes
			Front	Middle	Rear	
MITSUBISHI continued						
PAJERO continued	NK, NM DIESEL	11/96- 11/02	901002		901002	REAR SHAFT
	NK, NM V6 PETROL & TURBO DIESEL	11/96- 11/02	901014		901014	REAR SHAFT
SCORPION	GE	3/78-6/79	RUJ-1783		RUJ-1783	
	GH	7/79-10/80	RUJ-1786		RUJ-1786	
	GJ, GK, GL (MANUAL TRANSMISSION)	11/80-9/85	RUJ-1786		RUJ-1786	
	GJ, GK, GL (AUTO TRANSMISSION) MOST	11/80-9/85	RUJ-2045		RUJ-2045	76.5MM ACROSS CAPS
	GJ, GK, GL (AUTO TRANSMISSION) SOME	11/80-9/85	RUJ-1783		RUJ-1783	63.8MM ACROSS CAPS
SIGMA	GE, GH, GJ, GK, GN	10/77- 12/87	RUJ-1786		RUJ-1786	
STARION	JA, JB, JD	82-87	RUJ-2045	RUJ-2045	RUJ-2045	
TRITON	ME, MF, MG, MH, MJ 2WD 4CYL	86-	RUJ-2045	RUJ-2045	RUJ-2045	MEASURE U/JOINT DIMENSIONS TO ENSURE CORRECT SIZE
	Some can have		RUJ-1783	RUJ-1783	RUJ-1783	MEASURE U/JOINT DIMENSIONS TO ENSURE CORRECT SIZE
	MJ 2WD V6	9/92-	901002	901002	901002	
	ME, MF, MG 4WD	86-91	RUJ-1783		RUJ-1783	FRONT SHAFT
			RUJ-2045	RUJ-2045	RUJ-2045	REAR SHAFT (SOME V6 & TURBO DIESEL USE RUJ-3006)
	MH, MJ 4WD	9/92-	RUJ-1783		RUJ-1783	FRONT SHAFT
			901002	901002	901002	REAR SHAFT
	MK, ML V6 & TUR- BO DIESEL		901014	901014	901014	REAR SHAFT
NISSAN						
	B10,B20	1967-70	RUJ-1780		RUJ-1780	
1000-1200	B120	1970-74	RUJ-1780		RUJ-1780	JAPANESE PRODUCTION
	B120	1970-74	RUJ-1786		RUJ-1786	AUSTRALIAN PRODUCTION
		1974-79	RUJ-1786		RUJ-1786	AUSTRALIAN PRODUCTION
120Y, SUNNY	B210,VB210, B310	1974-81	RUJ-1780		RUJ-1780	SOME JAPANESE PRODUCTION
			902004		902004	MOST JAPANESE STAKED JOINT
1600, 180B, 200B	510,610B,810B	1974-81	RUJ-1781		RUJ-1781	JAPANESE PRODUCTION
	510, 610B, 810B	1974-81	RUJ-1786	RUJ-1786	RUJ-1786	AUSTRALIAN PRODUCTION
	510, 610B, 810B	1968-81			RUJ-2028	RS HALF SHAFTS
						SOME VEHICLES HAVE STAKED JOINTS - REF TO NOTE END OF SECTION
2000, 2300, 2400		1966-73	RUJ-1781		RUJ-1781	

APPLICATION LISTING

Make	Model	Year	Joint Position			Notes
			Front	Middle	Rear	
NISSAN continued						
240C, 260C, 280C, 240K		1973-77	RUJ-1781	RUJ-1781	RUJ-1781	
240K		1973-77			RUJ-2028	IRS HALF SHAFTS
200SX		1994 on				VEHICLES HAVE STAKED JOINTS -REF TO NOTE END OF SECTION
240Z, 260Z, 280Z, 280ZX		1967-86	RUJ-1781		RUJ-1781	
					RUJ-2028	IRS HALF SHAFTS
300ZX	Z31,Z32, Z31 TURBO	1986-97				VEHICLES HAVE STAKED JOINTS -REF TO NOTE END OF SECTION
BLUEBIRD	910	1981-86	RUJ-1786	RUJ-1786	RUJ-1786	
GAZELLE	S12	1984-88				VEHICLES HAVE STAKED JOINTS -REF TO NOTE END OF SECTION
NOMAD		1986-92	902004		902004	VEHICLES HAVE STAKED JOINTS -REF TO NOTE END OF SECTION
PINTARA	R31 MANUAL	1986-90	RC-100R231	RUJ-1786	RUJ-1786	RUBBER COUPLING
	R31 AUTO	1986-90	RC-BMW-002	RUJ-1786	RUJ-1786	RUBBER COUPLING
SKYLINE		1978-80	RUJ-1781	RUJ-1781	RUJ-1781	
		1978-80			RUJ-2028	IRS HALF SHAFTS
	R30	1981-86				VEHICLES HAVE STAKED JOINTS -REF TO NOTE END OF SECTION
	R31	1986-88	RUJ-2030	CV-856	RUJ-2030	
	R31	6/88-91	RUJ-2038	CV-855	RUJ-2038	
STANZA	A10	1978-83	RUJ-1781	RUJ-1781	RUJ-1781	JAPANESE PRODUCTION
	A10	1978-83	RUJ-1786	RUJ-1786	RUJ-1786	AUSTRALIAN PRODUCTION
COMMERCIAL						
520-620-720		1965-68	K5-LGB80R		K5-LGB80R	SOME MODELS
		1968-3/83	RUJ-1781	RUJ-1781	RUJ-1781	2WD & 4WD
720		4/83-85	RUJ-2028	RUJ-2028	RUJ-2028	
CABALL		1971-81	RUJ-2028		RUJ-2028	
CABSTAR	PF22 PETROL	1982-86	RUJ-1781		RUJ-1781	
	EF22 SD25 DIESEL	1982-86	RUJ-2040		RUJ-2040	

APPLICATION LISTING

Make	Model	Year	Joint Position			Notes
			Front	Middle	Rear	
NISSAN continued						
NAVARA	D21 2WD Z20, Z24 PETROL	1986-	901012	901012	901012	
	D21 2WD SD25. TD27 DIESEL	1986-92	RUJ-1781		RUJ-1781	
	D21 4WD	1985-8/87	RUJ-1781		RUJ-1781	FRONT SHAFT
		1985-8/87	RUJ-2028	RUJ-2028	RUJ-2028	REAR SHAFT
	D21 4WD	8/87-2/97	901012		901012	FRONT SHAFT
	D22 4 Cyl 4WD	3-97-	901012		901012	FRONT SHAFT
	D22 4 Cyl 2 & 4WD	3-97-	901012	901012	901012	REAR SHAFT
	D22 V6 3.0L 4WD	3-97-	901012		901012	FRONT SHAFT
	D22 V6 3.0L, 3.2L DIESEL 2&4WD	3-97-	RUJ-2028	RUJ-2028	RUJ-2028	REAR SHAFT
	D40 4WD 4.0L V6 PETROL	12/05-	5-178XP		5-178XP	REAR SHAFT
	D40 4WD 2.5L TURBO DIESEL	12/05-	RUJ-3002		RUJ-3002	REAR SHAFT
	D40 4WD ALL	12/05-	K5-13XR		K5-13XR	FRONT SHAFT
PATHFINDER	4 Cyl WNY21	1986-8/87	RUJ-1781		RUJ-1781	FRONT SHAFT
	4 Cyl WNY21	1986-8/87	RUJ-2028	RUJ-2028	RUJ-2028	REAR SHAFT
	4 Cyl	8/87-8/92	901012		901012	FRONT SHAFT
	4 Cyl	8/87-8/92	901012	901012	901012	REAR SHAFT
	V6 3.0L	8/92-11/95	901012		901012	FRONT SHAFT
	V6 3.0L	8/92-11/95	RUJ-2028	RUJ-2028	RUJ-2028	REAR SHAFT
	V6 3.3L	11/1995-	901012		901012	FRONT SHAFT
	V6 3.3L	11/1995-	RUJ-2028	RUJ-2028	RUJ-2028	REAR SHAFT
PATROL	G60	1959-80	5-178X		5-178X	FRONT & REAR SHAFT
	MQ	1980-87	RUJ-2028		RUJ-2028	FRONT & REAR SHAFT
	GQ 4.2L	1980-87	901003		901003	REAR SHAFT
	GQ 4.2L	1980-87	RUJ-2028		RUJ-2028	FRONT SHAFT
	GQ 3.0 & 2.8L	1980-87	RUJ-2028		RUJ-2028	FRONT & REAR SHAFT
	GU 2.8L TURBO DIESEL	12/97-5/00	RUJ-2028		RUJ-2028	FRONT & REAR SHAFT
	GU PETROL, DIESEL, TURBO DIESEL	12/97-	RUJ-2028		RUJ-2028	FRONT SHAFT
		12/97-	901003		901003	REAR SHAFT
TERRANO	TERRANO	1997-2000	TBA		TBA	SOME VEHICLES HAVE STAKED JOINTS -REF TO NOTE END OF SECTION
URVAN	E20, E23	1974-86	RUJ-1781		RUJ-1781	
	E24	4/87-93	901012		901012	SOME VEHICLES HAVE STAKED JOINTS - REF TO NOTE END OF SECTION
UTE	XFN	1986-91	RUJ-2038		RUJ-2038	

APPLICATION LISTING

Make	Model	Year	Joint Position			Notes
			Front	Middle	Rear	
NISSAN continued						
VANETTE	C20	1974-80	RUJ-1780		RUJ-1780	SOME MODELS
	C20,C120	1980-86	RUJ-1781		RUJ-1781	SOME MODELS
						SOME VEHICLES HAVE STAKED JOINTS - REF TO NOTE END OF SECTION
X-TRAIL			TBA		TBA	VEHICLES HAVE STAKED JOINTS - REF TO NOTE END OF SECTION
SOME VEHICLES HAVE STAKED JOINTS IN REAR SHAFT (UNSERVICEABLE WITHOUT SPECIAL TOOLING) REFER BEATTYS GROUP						
ROVER						
80, 95, 100, 110, 2000, 3500,3500S		1958-87	K5-13XR		K5-13XR	
	2000, 3500, 3500S ONLY	1963-87			5-178X	IRS HALF SHAFT
LANDROVER	SERIES I & 11	1948-62	K5-L4R		K5-L4R	FRONT & REAR SHAFT
	SERIES I & 11	1948-62	K5-GB35			FRONT AXLE SWIVEL JOINT
	SERIES IIA & III	1962-84	K5-13XR		K5-13XR	FRONT & REAR SHAFT
	SERIES IIA & III	1962-84	K5-GB35			FRONT AXLE SWIVEL JOINT
	110 & DEFENDER	1984-86	K5-13XR		K5-13XR	FRONT & REAR SHAFT
		86-	K5-L4R		K5-L4R	FRONT & REAR SHAFT
	FREELANDER	3/98-	K5-GB150		K5-GB150	FRONT SHAFT
		3/98-	CVJ N/A	K5-GB150	K5-GB150	3 PIECE REAR SHAFT
RANGEROVER		1972-85	K5-13XR		K5-13XR	FRONT & REAR SHAFT
		86-	K5-L4R		K5-L4R	FRONT & REAR SHAFT
DISCOVERY		1991-	K5-L4R		K5-L4R	FRONT & REAR SHAFT
SUBARU						
FORESTER	AWD	8/97-				VEHICLES HAVE STAKED JOINTS - REF TO NOTE END OF SECTION
IMPREZA	AWD	11/96-				VEHICLES HAVE STAKED JOINTS - REF TO NOTE END OF SECTION
LEONE, BRUMBY	4WD	1972-94	RUJ-1781	RUJ-1781	RUJ-1781	VEHICLES HAVE STAKED JOINTS - REF TO NOTE END OF SECTION
LIBERTY, OUTBACK	AWD	1991-	TBA		TBA	SOME VEHICLES HAVE STAKED JOINTS - REF TO NOTE END OF SECTION
L SERIES 4X4	LJ80, LJ81	1977-81	902005		902005	SOME VEHICLES HAVE STAKED JOINTS - REF TO NOTE END OF SECTION
			RUJ-1795		RUJ-1795	

APPLICATION LISTING

Make	Model	Year	Joint Position			Notes
			Front	Middle	Rear	
SUZUKI						
SIERRA 4X4	SJ410	1981-	RUJ-1795		RUJ-1795	FRONT & REAR SHAFT
	SJ413	1985-	K5-A557		K5-A557	FRONT & REAR SHAFT
	SJ413	1985-	RUJ-1795		RUJ-1795	FRONT & REAR SHAFT
VITARA 4X4	SWB 1.6L	1988-	K5-A557		K5-A557	FRONT & REAR SHAFT
	LWB 1.6L	1991-	K5-A557		K5-A557	FRONT & REAR SHAFT
	LWB V6	1995-	TBA		TBA	SOME VEHICLES HAVE STAKED JOINTS - REF TO NOTE END OF SECTION
X90		1996-	TBA		TBA	VEHICLES HAVE STAKED JOINTS - REF TO NOTE END OF SECTION
SOME VEHICLES HAVE STAKED JOINTS IN REAR SHAFT (UNSERVICEABLE WITHOUT SPECIAL TOOLING) REFER BEATTYS GROUP						
TOYOTA						
CELICA	TA, RA Series	1971-83	RUJ-1776	RUJ-1776	RUJ-1776	
		Some	902021	902021	902021	SOME VEHICLES HAVE STAKED JOINTS - REF TO NOTE END OF SECTION
COROLLA	KE10-70	1967-83	K5-A517		K5-A517	JAPANESE PRODUCTION
		1967-81	RUJ-1786		RUJ-1786	AUSTRALIAN PRODUCTION
	KE70, AE70,71,72	11/81-85	RUJ-1786	RUJ-1786	RUJ-1786	AUSTRALIAN PRODUCTION
	AE86 SPRINTER	1983-85	RUJ-2016	RUJ-2016	RUJ-2016	JAPANESE PRODUCTION
	AE95 4X4	1988-95	RUJ-1776		RUJ-1776	TAIL SHAFT - SOME
		1988-95	902021		902021	SOME VEHICLES HAVE STAKED JOINTS - REF TO NOTE END OF SECTION
CORONA	RT40-RT118	1964-5/79	RUJ-1776	RUJ-1776	RUJ-1776	JAPANESE PRODUCTION
	RT132-RT142, ST141, XT130-133	6/79-87	RUJ-1786	RUJ-1786	RUJ-1786	AUSTRALIAN PRODUCTION
			902021	902021	902021	SOME VEHICLES HAVE STAKED JOINTS - REF TO NOTE END OF SECTION
CORONA MKII	RT72, MX10-23 Series	1970-77	RUJ-1776		RUJ-1776	
CRESSIDA	MX32-MX73	1977-88	RUJ-1776	RUJ-1776	RUJ-1776	SOME MODELS
			902021	902021	902021	SOME VEHICLES HAVE STAKED JOINTS - REF TO NOTE END OF SECTION
CROWN	MS40,RS40	1964-68	RUJ-1776	RUJ-1776	RUJ-1776	JAPANESE PRODUCTION
	MS53, MS55 MS57, MS65	1968-74	RUJ-1786	RUJ-1786	RUJ-1786	AUSTRALIAN PRODUCTION
	MS83, MS85, MS111, MS112	1975-9/83	RUJ-2100	RUJ-2100	RUJ-2100	29 MM CAPS
	MS83, MS85, MS111, MS112	1975-9/83	RUJ-2041	RUJ-2041	RUJ-2041	32 MM CAPS
	MS123	10/83-88				VEHICLES HAVE STAKED JOINTS - REF TO NOTE END OF SECTION
LEXCEN	VN-VS	1989-	RUJ-2038	CV-855	RUJ-2038	

APPLICATION LISTING

Make	Model	Year	Joint Position			Notes
			Front	Middle	Rear	
TOYOTA continued						
RAV4		6/94-	902021	902021	902021	SOME VEHICLES HAVE STAKED JOINTS - REF TO NOTE END OF SECTION
SUPRA	MA60	1981-86	RUJ-1776	RUJ-1776	RUJ-1776	
	MA70, MA71	1986-92				SOME VEHICLES HAVE STAKED JOINTS - REF TO NOTE END OF SECTION
T18	TE72	1978-82	902021		902021	VEHICLES HAVE STAKED JOINTS - REF TO NOTE END OF SECTION
TARAGO/ PREVIA/ ESTIMA	YR20, YR21, CR21 ON	1982-90	RUJ-1776		RUJ-1776	SOME MODELS
	YR20	1982-90	RUJ-2016		RUJ-2016	SOME MODELS
		1982-90	902021		902021	STAKED JOINTS
	TCR10, 11	9/90-5/00				SOME VEHICLES HAVE STAKED JOINTS - REF TO NOTE END OF SECTION
TERCEL	4WD	1983-88	902021	902021	902021	VEHICLES HAVE STAKED JOINTS - REF TO NOTE END OF SECTION
COMMERCIALS						
BLIZZARD	LD10	1982-83	K5-A522		K5-A522	FRONT & REAR SHAFTS (EXTERNAL CIRCLIPS)
			RUJ-2023		RUJ-2023	SOME HAVE (INTERNAL CIRCLIPS)
BUNDERA		1984-93	RUJ-2100		RUJ-2100	FRONT & REAR SHAFTS
COASTER	JU18, RU18	1969-72	K5-A519	K5-A519	K5-A519	
	BU19, RU19	1972-77	RUJ-2041	RUJ-2041	RUJ-2041	
	All	1977-	RUJ-2041	RUJ-2041	RUJ-2041	
DYNA	All	1962-74	K5-A519	K5-A519	K5-A519	
	All	1974-84	RUJ-2041	RUJ-2041	RUJ-2041	
	Dyna 100	1986-01	RUJ-2041		RUJ-2041	
	Dyna 150	1985-88	RUJ-2041		RUJ-2041	
	Dyna 200, 300, 400	1985-	RUJ-2041	RUJ-2041	RUJ-2041	
HIACE	RH, LH	1967-89	RUJ-2016		RUJ-2016	
	RZH/LH103,113	1989-	RUJ-2100		RUJ-2100	SOME VEHICLES HAVE STAKED JOINTS - REF TO NOTE END OF SECTION
HILUX 2WD	RN13-RN41, LN30- LN56, YN55-YN58, LN85, YN85		RUJ-2016	RUJ-2016	RUJ-2016	
	2WD LN86, RN85, RN90, RZN147, 149, 154		RUJ-2100	RUJ-2100	RUJ-2100	SOME HAVE RUJ-2016

APPLICATION LISTING

Make	Model	Year	Joint Position			Notes
			Front	Middle	Rear	
TOYOTA continued						
HILUX 2WD continued	2WD KUN15 3.0, GGN15 4.0,TGN16R WORKMATE 2.7	3/05-	RUJ-2100	RUJ-2100	RUJ-2100	
HILUX 4WD, 4 RUNNER	4WD LN40, LN46	1979-7/83	RUJ-2100		RUJ-2100	REAR SHAFT
	4WD LN65, YN65, YN67, RN105, RN106, RN110 & RZN169, RZN174	8/83-	RUJ-2100		114-2501* X 2	FRONT SHAFT 13MM PIN SCV-35
		8/83-	RUJ-2100	RUJ-2100	RUJ-2100	REAR SHAFT
	4WD VZN167R	10/01-2/05	RUJ-2100		114-2501* X 2	FRONT SHAFT 12MM PIN SCV-34
	4WD VZN167R	10/01-2/05	RUJ-2100	902028	RUJ-2100	REAR SHAFT HAS A DOUBLE CARDAN ASSY IN MIDDLE
	4WD KUN26 3.0 DT, GGN25R 4.0 V6	3/05-	RUJ-2100	902028	RUJ-2100	F & R SHAFTS (SOME VEHICLES USE K5-13XR - EXTERNAL CIRCLIPS)
LANDCRUISER	All	1965-1/74	K5-A519		K5-A519	FRONT & REAR SHAFTS
	All	1/74-1/90	RUJ-2041		RUJ-2041	FRONT & REAR SHAFTS
	75 ,78,79 SERIES	1/90-	RUJ-2100		RUJ-2100	FRONT SHAFT
	75 ,78,79 SERIES	1/90-	RUJ-2041		RUJ-2041	REAR SHAFT
	80 SERIES	1/90-12/99	RUJ-2100		RUJ-2100	FRONT SHAFT
LANDCRUISER	80 SERIES	1/90-12/99	RUJ-2041		RUJ-2041	REAR SHAFT
	100 SERIES	3/98-	RUJ-2100		RUJ-2100	FRONT SHAFT
	100 SERIES	3/98-	RUJ-2100		RUJ-2100	REAR SHAFT
	HDJ100, HZJ105, U ZJ100, FZJ105	7/98-8/02	RUJ-2041		RUJ-2041	REAR SHAFT (SWING OUT BACK DOOR
	UZJ100	2002-2006	RUJ-2100		RUJ-2100	REAR SHAFT
LITE ACE	All	1970-85	RUJ-1776		RUJ-1776	
		1985-	902021		902021	SOME VEHICLES HAVE STAKED JOINTS - REF TO NOTE END OF SECTION
PRADO AI		1996-	RUJ-2100		RUJ-2100	FRONT SHAFT
			902028		RUJ-2100	REAR SHAFT
* Double Cardan Assembly Requires 2 Pieces of 114.2501 and a Repair Kit						
STOUT	RK101	1967-79	K5-A519		K5-A519	
	RK110	3/79-84	RUJ-2041		RUJ-2041	
TOWN ACE		1982-7/85	RUJ-2016		RUJ-2016	
		8/85-88				SOME VEHICLES HAVE STAKED JOINTS - REF TO NOTE END OF SECTION
SCV-34 with 12mm Pins, or SCV-35 with 13mm Pins						
SOME VEHICLES MAY HAVE STAKED JOINTS (UNSERVICEABLE WITHOUT STAKING TOOLING) REFER BEATTYS GROUP FOR SHAFT REPLACEMENT OPTIONS						

APPLICATION LISTING

Make	Model	Year	Joint Position			Notes
			Front	Middle	Rear	
TRIUMPH						
DOLOMITE	ALSO SPRINT	1975-78	K5-LGB80R		K5-LGB80R	
SPIRFIRE	GTS	1962-81	K5-LGB80R		K5-LGB80R	INC IRS HALF SHAFTS
TR4		1961-66	K5-L4R		K5-L4R	
TR4A, TR5, TR6		1966-77	K5-L4R		K5-L4R	NC IRS HALF SHAFTS
STAG		1972-78	K5-L4R		K5-L4R	NC IRS HALF SHAFTS
2000, 2500 MK1,2		1966-78	K5-LGB80R		K5-LGB80R	
		1966-78	RUJ-1786		RUJ-1786	
2000, 2500, MK1,2		1966-78			K5-L4R	IRS HALF SHAFTS
TR7		1978-81	K5-LGB80R		K5-LGB80R	
VOLVO						
140 SERIES	ALL	1967-73	K5-LGB80R		K5-LGB80R	
	B20E,CB20	1973-75	K5-13XR	K5-13XR	K5-13XR	
	B20,B20A	1973-75	K5-LGB80R	K5-LG-B80R	K5-L4R	
160 SERIES	164E,164TE,B30E	1972-75	K5-13XR	K5-13XR	K5-13XR	
240 SERIES	B21A, B23E, B230E, B230F	1975-87	K5-LGB80R	K5-LG-B80R	K5-L4R	
	B21E	1975-80	K5-13XR	K5-13XR	K5-13XR	
260 SERIES	262,264,265	1975-86	K5-13XR	K5-13XR	K5-13XR	
740, 760 SERIES		1983-90	K5-13XR	K5-13XR	K5-13XR	SOME MODELS
		1983-90	K5-13XR	K5-L4R	K5-L4R	SOME MODELS
		1983-90	K5-L4R	K5-L4R	K5-L4R	SOME MODELS

PART NO. INDEX

PART NO.	PAGE NO	PART NO.	PAGE NO	PART NO.	PAGE NO	PART NO.	PAGE NO
114-10000	26	114-3105	12	114-6285	24	369.10	14
114-10003	26	114-3105SP	12	114-7000RHWD	18	369.30	17
114-10007	26	114-3120	13	114-7126	25	369-37	19
114-10011	26	114-3121	24	114-7126-4A	25	393-85	23
114-10011P	26	114-3125	23	114-7126P	25	401001	9
114-10011SP	26	114-4100	24	114-7126SP	25	401005	6
114-10033	26	114-4105	24	114-7205	25	401006	8
114-1004	8	114-4109	13	114-7206	25	401007	12
114-10500	26	114-4110	24	114-7207	25	403001	20
114-11002	26	114-4113	24	114-7208	25	404001	25
114-12000	26	114-4141	24	114-7209	25	404002	6
114-12002	26	114-5031	24	114-7294	18	404003	8
114-12002SP	26	114-5109	15	114-8014	18	405001	12
114-14000	26	114-5110	15	114-8113	25	405002	12
114-15002	26	114-5122	24	114-8113P	25	407001	7
114-15002SP	26	114-5127	24	114-8113SP	25	409001	20
114-15003	26	114-5132	15	114-8205	25	409003	19
114-15003SP	26	114-5148	24	114-8205P	25	5-124X	22
114-1501	8	114-5154	15	114-8206	25	5-134X	10
114-162	15	114-5173	24	114-8207	25	5-134XSP	10
114-2101	9	114-5177	24	114-8207-4A	25	5-150X	10
114-2110	23	114-5177P	24	114-8208	25	5-150XNF	10
114-2111	9	114-5177SP	24	114-8508	26	5-155X	16
114-2111-1A	9	114-596	11	114-8514	25	5-155XR	16
114-2114	9	114-596SP	11	114-8516	25	5-165X	18
114-2114-1A	9	114-6103	24	114-8516P	25	5-170X	7
114-2116	23	114-6104	24	114-8516SP	26	5-170X-1A	7
114-2117	23	114-6107	15	114-9014	26	5-170XSP	7
114-2185	23	114-6114	24	114-9014P	26	5-174X	9
114-2186	23	114-6128	24	114-9014SP	26	5-178-1A	14
114-2198	9	114-6128P	24	114-9016	26	5-178XR	14
114-232	13	114-6128SP	24	114-9016P	26	5-178XRRS	14
114-232SP	13	114-6135	15	114-9016SP	26	5-185X	21
114-2501	12	114-6143	24	114-9017	26	5-186X	22
114-2531	10	114-6143P	24	114-9017P	26	5-187X	22
114-3100	23	114-6150	15	114-9026	26	5-188X	16
114-3101	23	114-6162	24	114-9500	26	5-188XR	16
114-3102	12	114-6163	24	114-9500SP	26	5-220X	16

PART NO. INDEX

PART NO.	PAGE NO	PART NO.	PAGE NO	PART NO.	PAGE NO	PART NO.	PAGE NO
5-221X	16	5-515X	20	802006	13	802038S	14
5-248X	8	5-54X	22	802006-1A	13	802039	12
5-260X	9	5-618XSG	11	802006-011	13	802039-1A	12
5-264X	7	5-625XSD	10	802007	16	802039-3A	12
5-279X	19	5-625XSG	10	802007-011	16	802040	16
5-279XP	19	5-627XSD	14	802008	17	802040S	16
5-280X	20	5-627XSG	14	802009	17	802041	22
5-280XP	20	5-632XSD	10	802010	17	802041S	22
5-280XR	20	5-633XSP	11	802011	18	802042	13
5-281X	20	5-641XSG	14	802012	19	802043	19
5-281XP	20	5-64XSD	14	802013	19	802043S	19
5-281XR	20	5-674X	19	802016	20	802044-011	11
5-291X	10	5-674XP	19	802016S	20	802045	16
5-297X	14	5-675X	20	802019	22	802046	19
5-308X	22	5-675XP	20	802019S	22	802047	7
5-314X	11	5-675XR	20	802020	16	802048	11
5-3212X	16	5-676X	20	802021	19	802049	11
5-324X	21	5-676XP	21	802022	17	802050	19
5-326X	22	5-677X	20	802023	17	802051	18
5-327X	22	569-32	16	802024	6	802052	22
5-328X	16	5-693X	16	802024-1A	6	802054	18
5-330X	18	5-7166X	14	802025	16	802054S	18
5-331X	18	5-88X	16	802026	17	802056	18
5-339X	23	687-50	20	802027	15	802057	18
5-345X	14	701006	8	802028	16	802057S	18
5-346X	14	701153	14	802029	20	802059	11
5-347X	16	701627C	6	802029S	20	802061	16
5-348X	16	702851	12	802030	17	802062	18
5-355X	11	703188	15	802031	15	802063	8
5-356X	10	70GUA6	8	802032	13	802064	14
5-357X	14	801001	22	802033	17	802065	17
5-372X	23	801001S	22	802034	16	802066	20
5-407X	20	802001	6	802035	13	802067	7
5-430X	7	802002	6	802036	22	802068	8
5-443X	9	802003	7	802036S	22	802069	11
5-460X	10	802004	7	802037	6	802070	15
5-510X	20	802004-1A	7	802038	14	803001	20
5-515X-CAT	20	802005	12	802038R	14	803002	22

PART NO. INDEX

PART NO.	PAGE NO	PART NO.	PAGE NO	PART NO.	PAGE NO	PART NO.	PAGE NO
804001	25	902031	17	912003	18	K5-A530XSD	10
901001	6	902032IC	6	912004	15	K5-A532	8
901002	13	902152	6	920047	6	K5-A537	11
901003	15	902260	7	930106	14	K5-A538	16
901004	6	902275	9	941118	18	K5-A541	13
901005	8	902456	8	948135	19	K5-A546	6
901012	11	902472	8	948135S	20	K5-A547	18
901013	13	902474	8	950132	17	K5-A548	21
901014	13	902488	8	950232	19	K5-A549	6
901015	15	9026BL	9	957172	22	K5-A551	6
901153	13	902774	11	968166	22	K5-A553	7
901540	6	902780	11	CP20-RPLS	21	K5-A554	7
901547	6	902782	11	CP20-RPLSG	21	K5-A557	8
901900	18	902788	11	CP25-RPLS	21	K5-A558	8
901954	6	902875	12	CP25-RPLSG	21	K5-A559	8
902001	6	902878	12	CP35N	15	K5-A561	11
902002	6	903001	21	CP44R	15	K5-A562	12
902004	6	903002	21	CP55N	17	K5-A563	15
902005	6	903003	21	CP58WB-29	25	K5-A564	15
902006	7	903004	19	CP58WB-29P	25	K5-A566	17
902007	7	903005	21	CP58WB-37	25	K5-A567	17
902008	8	903006	21	CP58WB38	25	K5-A568	17
902009	8	903007	22	CP6N	20	K5-A569	17
902010	8	903008	22	CP750NP	18	K5-A571	17
902011	8	903009	21	CP850N	20	K5-A572	17
902013	15	903049	12	CPL-10N	7	K5-A573	17
902014	6	903087	13	CPL-14N	13	K5-A574	18
902015	17	903087A	14	K5-13XR	10	K5-A575	18
902017	18	903088	14	K5-13XR-1A	10	K5-A576	19
902018	8	903092	14	K5-13XRR	10	K5-A577	19
902019	17	903293	15	K5-13XRRS	10	K5-A578	19
902020	6	903293-1	15	K5-A510	6	K5-A579	19
902021	7	903396	15	K5-A517	6	K5-A580	19
902022	19	904001	25	K5-A519	13	K5-A581	19
902024	9	904002	25	K5-A522	12	K5-A582	20
902025	6	904003	25	K5-A522/13XR	10	K5-A583	21
902026	11	904004	25	K5-A523	17	K5-A584	21
902030	18	905375	13	K5-A530	10	K5-A585	13

PART NO. INDEX

PART NO.	PAGE NO	PART NO.	PAGE NO	PART NO.	PAGE NO	PART NO.	PAGE NO
K5-A587	6	K5-A718	23	RUJ-1776	9	RUJ-2100-13XR	10
K5-A588	7	K5-A719	23	RUJ-1780	6	RUJ-2100-1A	13
K5-A589	7	K5-A725	17	RUJ-1781	8	RUJ-2100R	13
K5-A590	11	K5-A727	11	RUJ-1783	8	RUJ-2500	12
K5-A590S	11	K5-A727R	11	RUJ-1783SP	8	RUJ-2500R	12
K5-A591	14	K5-A727SP	11	RUJ-1784	8	RUJ-2505	13
K5-A592	15	K5-A729	16	RUJ-1784SP	8	RUJ-3000	11
K5-A593	17	K5-A729SP	16	RUJ-1786	8	RUJ-3000SP	11
K5-A594	18	K5-A730	16	RUJ-1786R	8	RUJ-3001	14
K5-A595	18	K5-A730-1A	16	RUJ-1788	9	RUJ-3002	11
K5-A605	19	K5-A730R	16	RUJ-1794	9	RUJ-3002S	11
K5-A615	7	K5-A730S	16	RUJ-1795	8	RUJ-3003	15
K5-A622	18	K5-A790	23	RUJ-1797	7	RUJ-3004	15
K5-A622S	18	K5-A802	22	RUJ-1800	6	RUJ-4000	13
K5-A625	23	K5-A802S	22	RUJ-2009	9	RUJ-4002	13
K5-A625-4A	23	K5-A808	16	RUJ-2016	9	RUJ-4003	24
K5-A626	23	K5-A820	23	RUJ-2016SP	9	RUJ-4005	13
K5-A627	23	K5-A827	19	RUJ-2023	12	RUJ-4007	15
K5-A628	23	K5-A841	15	RUJ-2023SP	12	RUJ-4008	14
K5-A629	23	K5-A842	13	RUJ-2027	9	RUJ-4009	17
K5-A630	22	K5-A844	6	RUJ-2028	12	RUJ-8002	21
K5-A632	17	K5-GB10RR	14	RUJ-2028SP	12	SPL170X	21
K5-A634	22	K5-GB10RRS	14	RUJ-2029	11	SPL170XP	21
K5-A639	17	K5-GB10R-4A	14	RUJ-2030	9	SPL250X	22
K5-A64	7	K5-GB150	7	RUJ-2030R	9	SPL250XP	22
K5-A643	22	K5-GB15R	17	RUJ-2032	9	SPL90X	18
K5-A643S	22	K5-GB22R	17	RUJ-2033	13	U-149	7
K5-A701	6	K5-GB36R	10	RUJ-2034	9	U-149-3	8
K5-A707	23	K5-LGB80R	7	RUJ-2038R	12	U-160	7
K5-A708	23	K5-LGB80R-1A	7	RUJ-2038S	12	U-166	7
K5-A709	23	K5-LGB80RP	7	RUJ-2039	10	U-172	12
K5-A711	23	K5-L4R	9	RUJ-2039SP	10	U-188	16
K5-A712	23	K5-L4RP	9	RUJ-2040	8	U-196	7
K5-A713	23	RUJ-1500	7	RUJ-2041	15	U-3180	22
K5-A714	23	RUJ-1501	6	RUJ-2041R	15	U-3208	23
K5-A715	23	RUJ-1758	9	RUJ-2045	8	U-3250	23
K5-A716	23	RUJ-1764	8	RUJ-2049	9	U-3285	23
K5-A717	23	RUJ-1766	9	RUJ-2051	12	U-3315	23

PART NO. INDEX

PART NO.	PAGE NO	PART NO.	PAGE NO
U-380	18	U-901C	6
U-381	21	U-901S	6
U-384	19	U-901SL	6
U-385	17	UJ641	8
U-386	21		
U-501	20		
U-728	12		
U-728-1	12		
U-729	13		
U-730	17		
U-737	18		
U-739	21		
U-741	9		
U-742	13		
U-743	16		
U-744	17		
U-746	18		
U-747	18		
U-752-1	17		
U-753	19		
U-756	21		
U-756S	21		
U-761	21		
U-761S	21		
U-763	22		
U-763S	22		
U-764	17		
U-765	19		
U-765-2A	19		
U-765S	19		
U-767	19		
U-767S	19		
U-810	19		
U-811	21		
U-812	21		
U-813	22		
U-813S	22		
U-901	6		

We're here for the long haul.

The Beattys logo consists of the word "Beattys" in a white, sans-serif font. The letter "B" is stylized with a small orange square at its top-left corner. The logo is centered within a dark grey circular background.

Beattys Group Ltd (New Zealand)

4 Harbour Ridge Drive, Wiri, Auckland 2104
PO Box 97410, Manukau City, Auckland 2241

Phone +64 9 263 7761

Fax +64 9 262 0970

sales@beattys.com